

LoRa Radio Networks

Tomáš Rosa

Head of Cryptology and Biometrics Competence Centre of Raiffeisen Bank International
Department of Algebra, Faculty of Mathematics and Physics, Charles University in Prague

Cautionary Note

- **LoRa** ~ Long Range (radio)
 - physical layer based on Chirp Spread Spectrum radio
 - many different networks can be based on LoRa PHY
 - including star as well as mesh and ad-hoc mesh topologies
- **LoRaWAN** ~ Long Range Wide-Area Network
 - particular wireless network architecture with a star topology based on LoRa PHY
- We shall not mix these two terms

LoRa (Long Range) PHY Origin

"...The story of LoRa began in 2009, when two friends in France ... Despite encountering resistance, ... **Nicolas Sornin and Olivier Seller** continued dedicating their time to turn the idea into a reality. In 2010, Nicolas and Olivier met their third partner, **François Sforza**, and together they started the company Cycleo. ... **[Grenoble, FR]**"

"... Semtech acquired Cycleo in May 2012. ... **[Camarillo, California, USA]**"

(12) **United States Patent**
Sforza

(10) **Patent No.:** US 8,406,275 B2
(45) **Date of Patent:** Mar. 26, 2013

(54) **COMMUNICATIONS SYSTEM**

(75) Inventor: **Francois Sforza**, Nice (FR)

(73) Assignee: **Nanoscale Labs**, La Tronche (FR)

(*) Notice: Subject to any disclaimer, the term of this patent is extended or adjusted under 35 U.S.C. 154(b) by 410 days.

(21) Appl. No.: **12/720,139**

(22) Filed: **Mar. 9, 2010**

(65) **Prior Publication Data**

US 2011/0064119 A1 Mar. 17, 2011

(30) **Foreign Application Priority Data**

Jul. 2, 2009 (EP) 09305641

(51) **Int. Cl.**
H04B 1/00 (2006.01)

(52) **U.S. Cl.** **375/139**

(58) **Field of Classification Search** 375/139,
375/371, 298; 370/441, 307, 516
See application file for complete search history.

(56) **References Cited**

U.S. PATENT DOCUMENTS

5,550,549 A * 8/1996 Procter et al. 342/47
6,252,882 B1 * 6/2001 Matsui 370/441
6,549,562 B1 * 4/2003 Olaker et al. 375/139
6,614,864 B1 * 9/2003 Raphaeli et al. 375/371
6,940,893 B1 * 9/2005 Pinkney et al. 375/139

2007/0126622 A1 * 6/2007 Nallapureddy et al. 342/92
2008/0194215 A1 * 8/2008 Bolanos 455/115.1
2008/0309543 A1 * 12/2008 Schaffner 342/21

FOREIGN PATENT DOCUMENTS

EP 0 952 713 10/1999

OTHER PUBLICATIONS

European Search Report dated Nov. 25, 2009, from corresponding European application.

* cited by examiner

Primary Examiner — David C. Payne
Assistant Examiner — Wednel Cadeau

(74) *Attorney, Agent, or Firm* — Young & Thompson

(57) **ABSTRACT**

A communications system includes a modulator for generating a chirp signal aimed at spreading the frequency spectrum of an information signal over a specified spectral bandwidth of a communications channel. The chirp signal has initial and final instantaneous frequency. The chirp signal is controlled from an in-phase control signal and a quadrature-phase control signal to have, in a complex plane, constant amplitude and instantaneous phase. The instantaneous frequency is defined by the speed the instantaneous phase is changed in the complex plane by the in-phase and quadrature-phase control signals; the instantaneous frequency is linearly changed between initial and instantaneous frequencies over the whole duration of the chirp signal; the initial and final instantaneous phases of the chirp signal are identical. The communications system also described an adapted demodulator capable of working even in presence of a significant frequency and/or timing offset between the transmitting and receiving clocking systems.

20 Claims, 11 Drawing Sheets

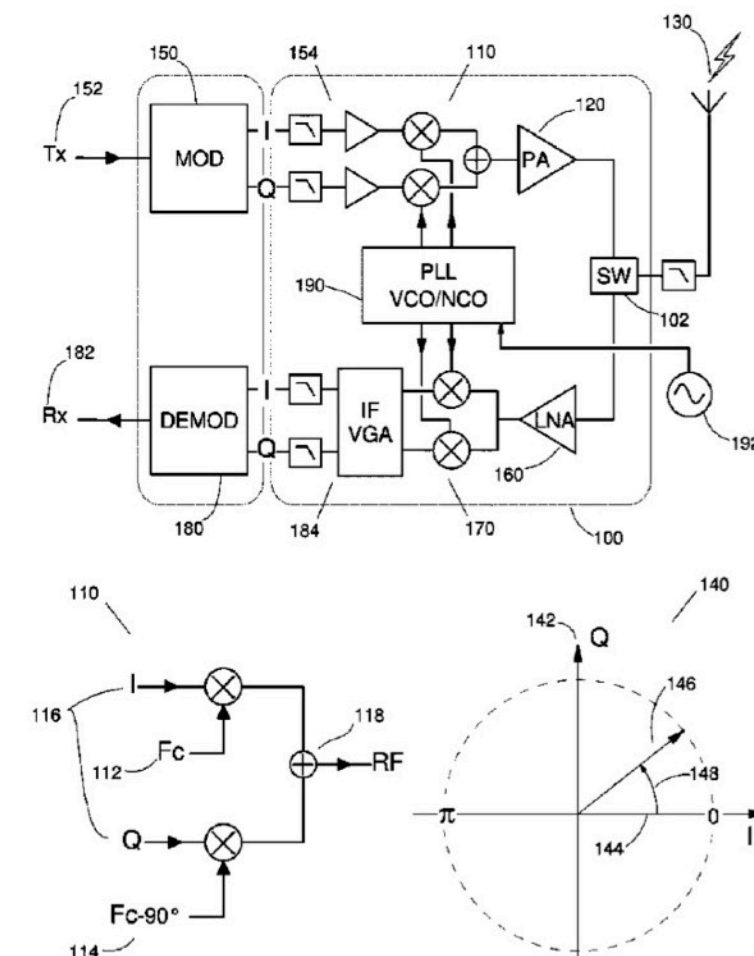

(12) **United States Patent**
Seller et al.

(10) **Patent No.:** US 9,252,834 B2
(45) **Date of Patent:** Feb. 2, 2016

(54) **LOW POWER LONG RANGE TRANSMITTER**

(56) **References Cited**

(71) Applicants: **Olivier B. A. Seller**, Saint Soulle (FR);
Nicolas Sornin, La Tronche (FR)

(72) Inventors: **Olivier B. A. Seller**, Saint Soulle (FR);
Nicolas Sornin, La Tronche (FR)

(73) Assignee: **Semtech Corporation**, Camarillo, CA (US)

(*) Notice: Subject to any disclaimer, the term of this patent is extended or adjusted under 35 U.S.C. 154(b) by 0 days.

(21) Appl. No.: **14/170,170**

(22) Filed: **Jan. 31, 2014**

(65) **Prior Publication Data**

US 2014/0219329 A1 Aug. 7, 2014

(30) **Foreign Application Priority Data**

Feb. 5, 2013 (EP) 20130154071

(51) **Int. Cl.**
H04B 1/66 (2006.01)
H03M 13/27 (2006.01)
H04B 1/69 (2011.01)
H03M 5/14 (2006.01)

(52) **U.S. Cl.**
CPC . **H04B 1/66** (2013.01); **H03M 5/14** (2013.01);
H03M 13/276 (2013.01); **H03M 13/2721**
(2013.01); **H04B 1/69** (2013.01); **H04B**
2001/6912 (2013.01)

(58) **Field of Classification Search**
CPC H04B 1/66; H04B 1/69; H04B 2001/6912;
H03M 13/2721; H03M 13/276; H03M 5/14
See application file for complete search history.

U.S. PATENT DOCUMENTS

5,852,418 A * 12/1998 Ferrell et al. 342/202
6,549,562 B1 * 4/2003 Olaker et al. 375/139
6,614,853 B1 * 9/2003 Koslar et al. 375/271
6,940,893 B1 9/2005 Pinkney et al.
8,718,117 B2 * 5/2014 Hiscock 375/139
2002/0003846 A1 * 1/2002 Khayrallah et al. 375/341
2007/0002969 A1 * 1/2007 Jeong et al. 375/298
2007/0274338 A1 * 11/2007 Sebire et al. 370/466
2009/0180518 A1 * 7/2009 Ishii et al. 375/130
2011/0064119 A1 * 3/2011 Sforza 375/139

FOREIGN PATENT DOCUMENTS

EP 0952713 A2 10/1999
EP 2278724 A1 1/2011
EP 2449690 A1 5/2012
WO WO-0158024 A1 8/2001
WO WO-2011000936 A1 1/2011

* cited by examiner

Primary Examiner — Kenneth Lam

(74) *Attorney, Agent, or Firm* — Blank Rome LLP

(57) **ABSTRACT**

A transmitter device arranged to encode a set of digital input data into a succession of modulated chirps, whereby said digital input data are encoded according to a Gray code into codewords (320, 321, 322) having a plurality of bits, and having an interleaver that distributes the bits (C_{00}, \dots, C_{nm}) of each codeword into a series of digital modulation values (S_0, \dots, S_7), at different bit positions, and to synthesize a series of modulated chirps whose cyclical shifts are determined by the modulation values. A special frame structure is defined in order to ensure high robustness, and variable bit-rate flexibility.

15 Claims, 3 Drawing Sheets

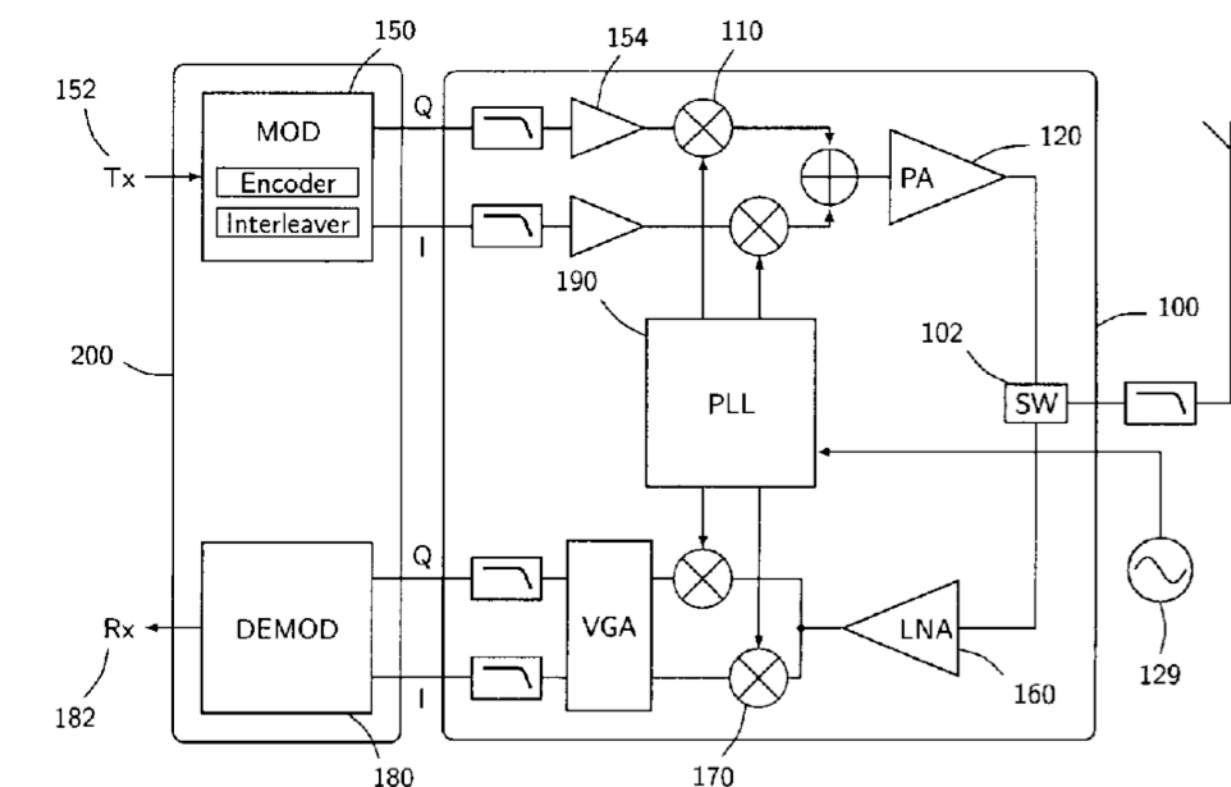

So, the EU independence and sovereignty has its limits here

"... Semtech acquired Cycleo in May 2012. ... [Camarillo, California, USA]"

$$e^{i\varphi(t)} = \cos \varphi(t) + i \sin \varphi(t)$$

in-phase component

quadrature ($\frac{\pi}{2}$ shift) component

radio terminology

LoRa Radio: Basal UpChirp

instant frequency
plane



signal plane

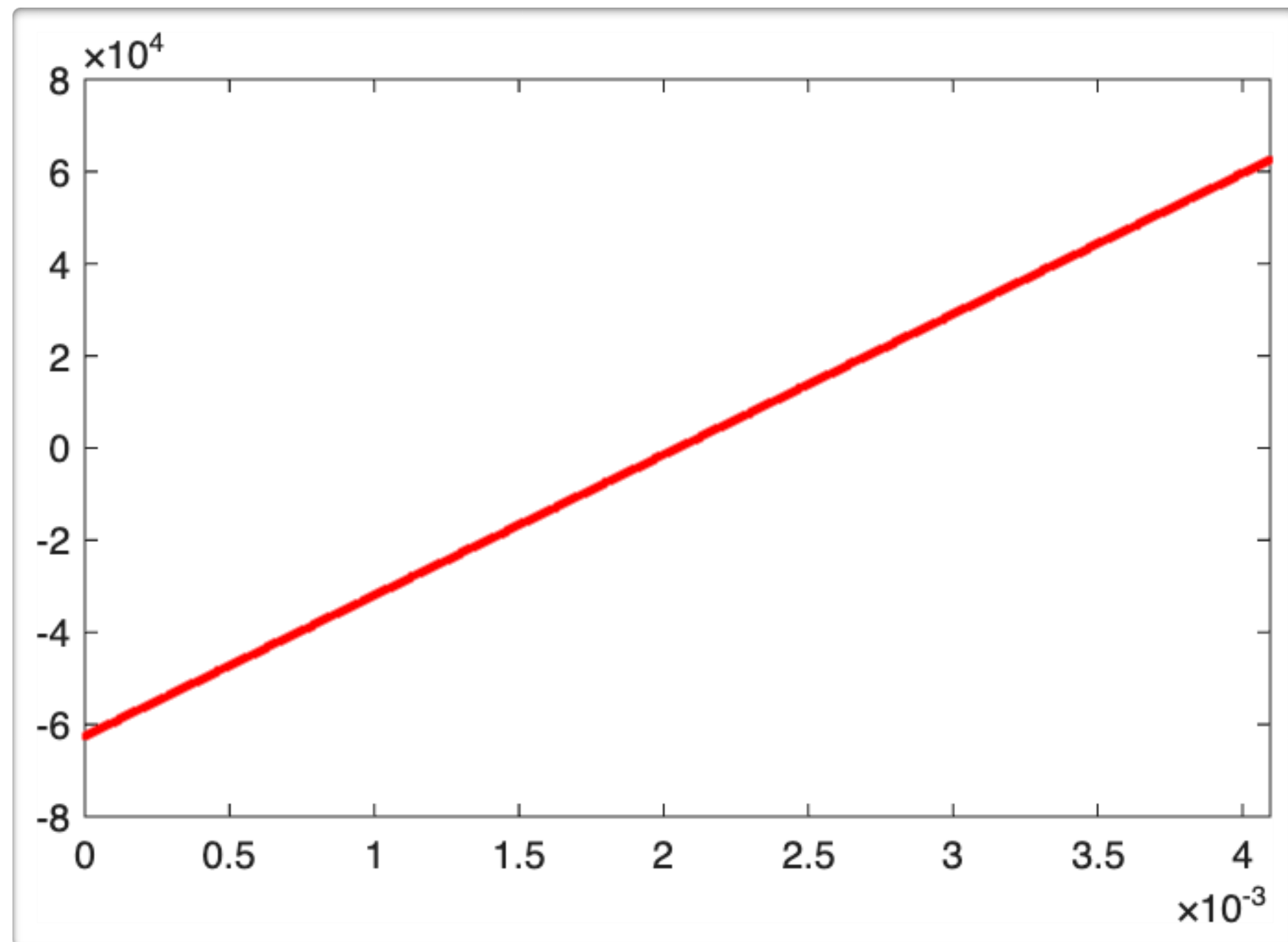
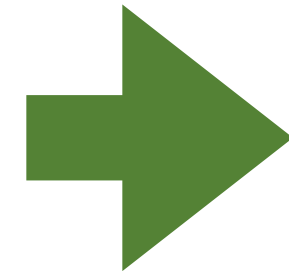

in-phase

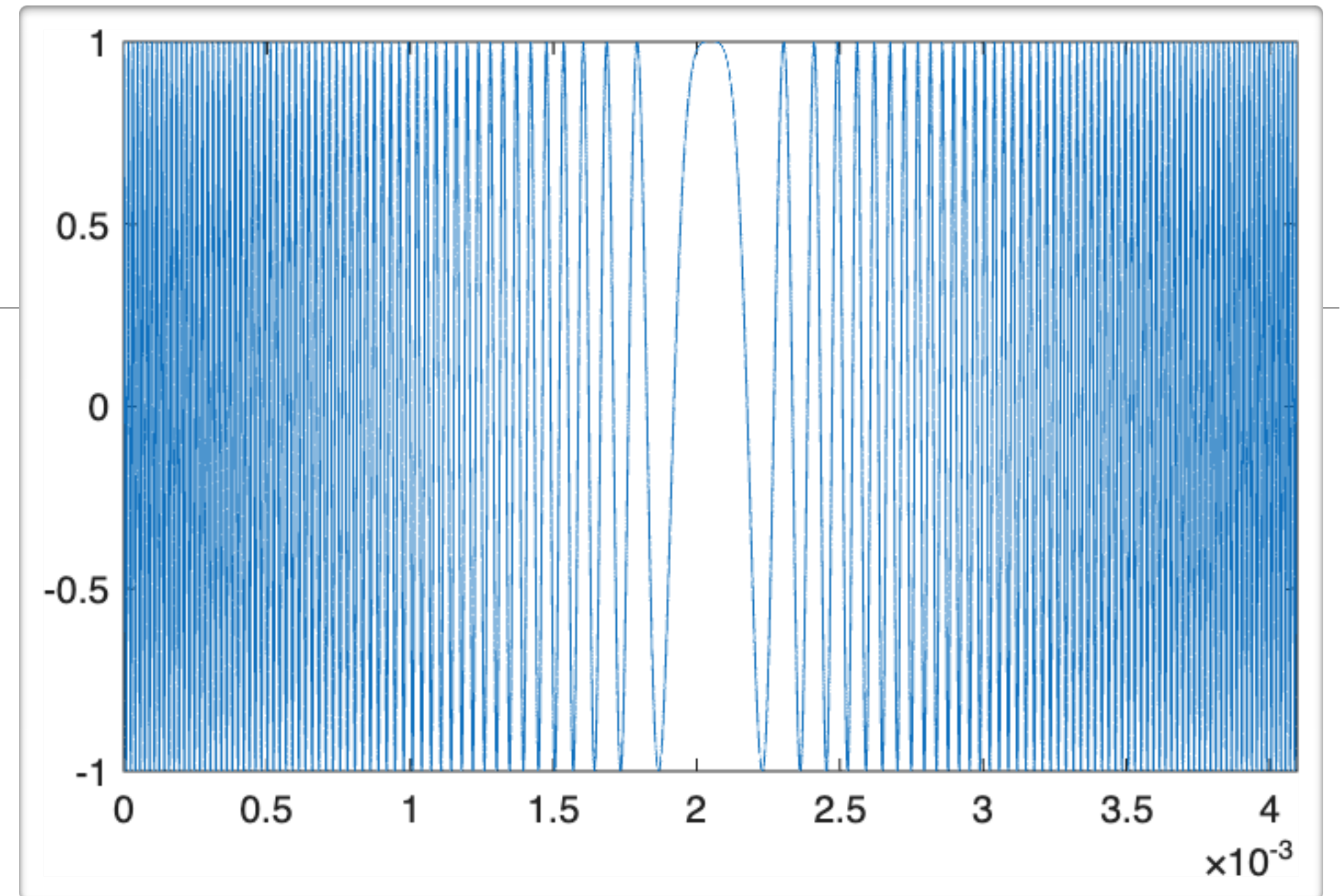

quadrature

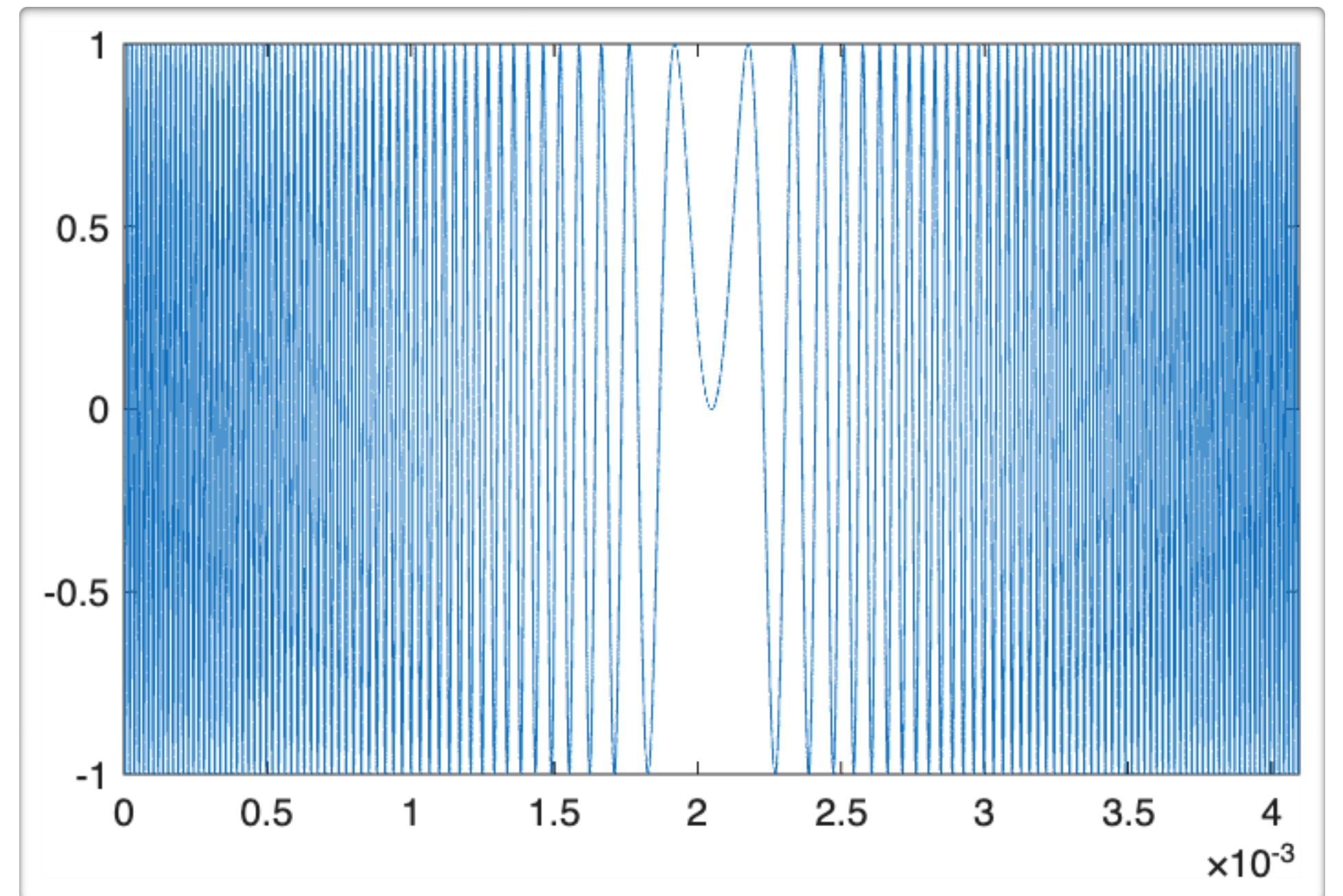

SF = 9, BW = 125 kHz

LoRa Radio: Basal DownChirp

instant frequency

plane



signal plane

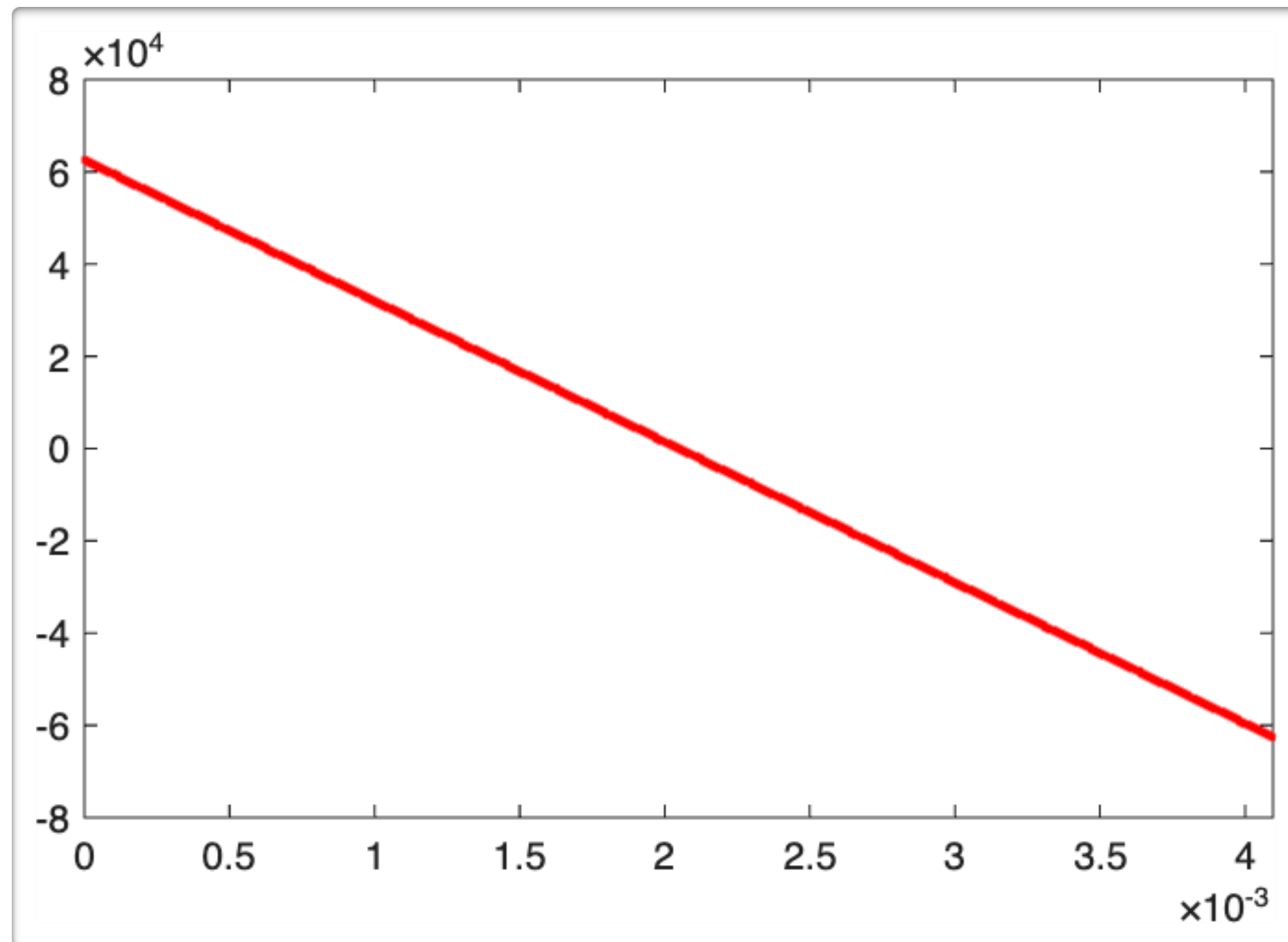
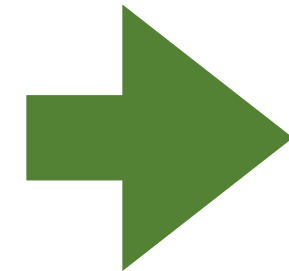

in-phase

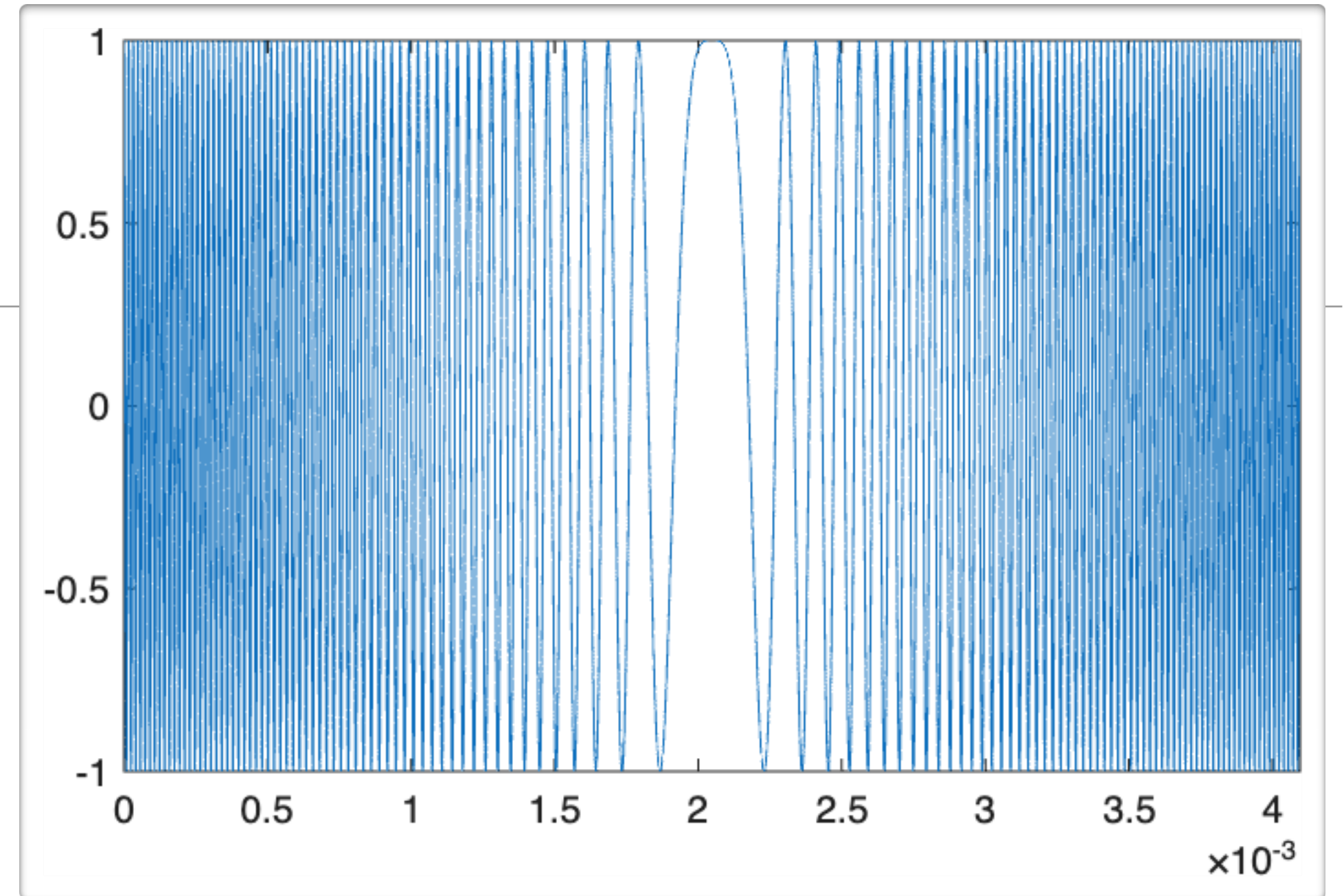

quadrature

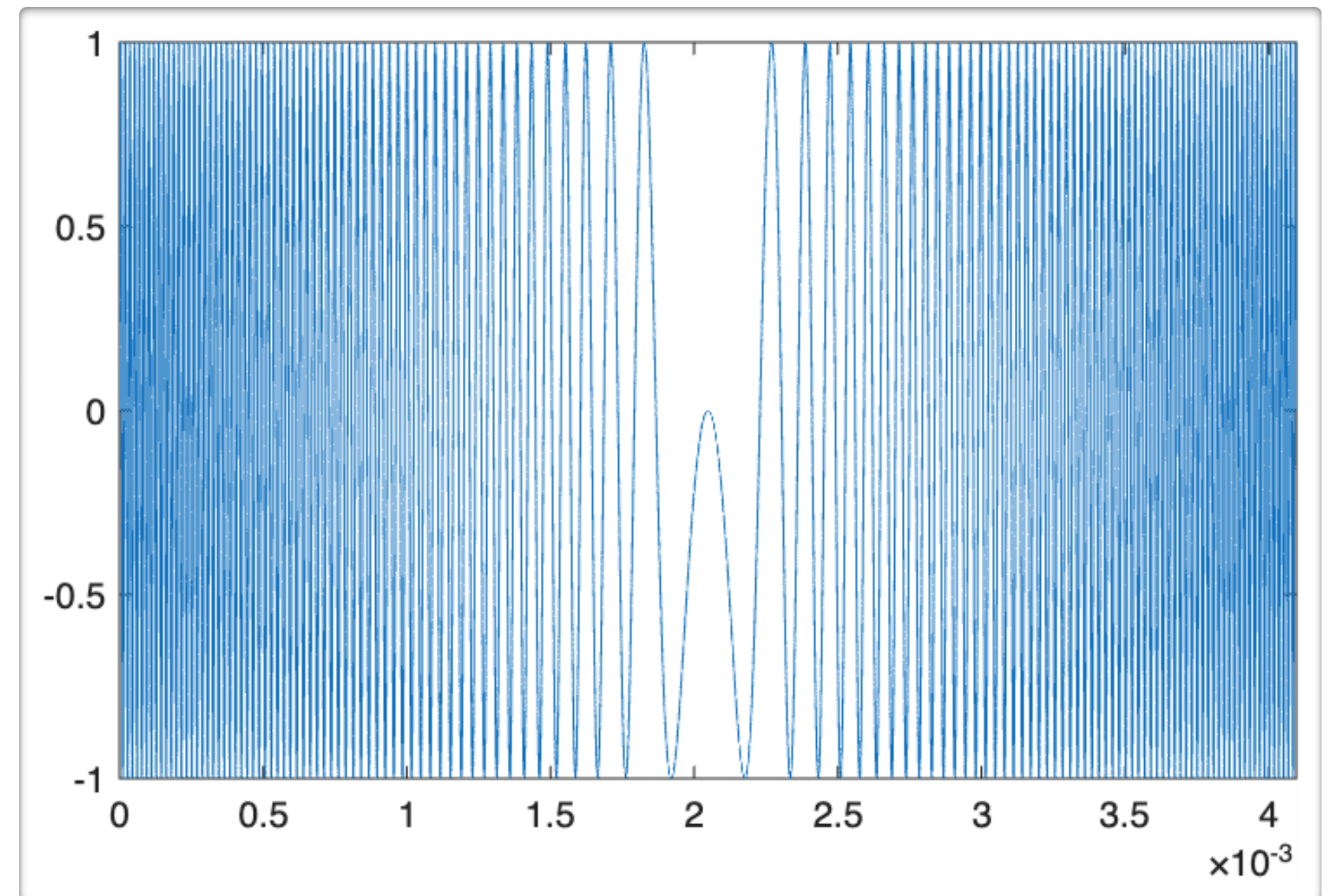

SF = 9, BW = 125 kHz

LoRa Core Modulator Parameters

- **Spreading Factor (SF)**

- governs the spreading ratio of the modulated chirp signal
- technically, it is the number of raw data bits per modulation symbol
- possible values: 5, 6, 7, 8, 9, 10, 11, 12

- **Bandwidth (BW)**

- sets the symmetric bandwidth predominantly occupied by the chirp
- possible values (kHz): 7.81, 10.42, 15.63, 20.83, 31.25, 41.67, 62.5, 125, 250, 500

Defining equation for the modulated symbol (chirp) period: $T_s = \frac{2^{SF}}{BW}$

LoRa Complex Modulated Signal in Baseband (UpChirp based)

$$f_S(t) = \frac{BW}{T_s}t - \frac{BW}{2} + \frac{S}{T_s} - BW \cdot u(t - t_{fold}), \quad S \in \{0, 1, \dots, 2^{SF} - 1\}, \quad 0 \leq t < T_s$$

$$\varphi_S(t) = 2\pi \int_0^t f_S(\tau) d\tau = 2\pi \left(\frac{BW}{2T_s}t^2 - \frac{BW}{2}t + \frac{S}{T_s}t - BW \cdot (t - t_{fold}) u(t - t_{fold}) \right)$$

$$x_S(t) = e^{i\varphi_S(t)} = e^{i2\pi \left(\frac{BW}{2T_s}t^2 - \frac{BW}{2}t + \frac{S}{T_s}t - BW \cdot t \cdot u(t - t_{fold}) \right)}$$

$$T_s = \frac{2^{SF}}{BW}, \quad t_{fold} = T_s - \frac{S}{BW}$$

$$BW \cdot t_{fold} = (2^{SF} - S) \in \mathbb{Z}$$

Real Passband Quadrature Modulated Signal Form

$$y_s(t) = \Re \left\{ x_s(t) \cdot e^{i2\pi f_c t} \right\} = \Re \left\{ e^{i2\pi \left(\frac{BW}{2T_s} t^2 - \frac{BW}{2} t + \frac{S}{T_s} t - BW \cdot t \cdot u(t - t_{fold}) + f_c \cdot t \right)} \right\}$$

unless stated otherwise, however, we work with complex baseband signals in the following slides

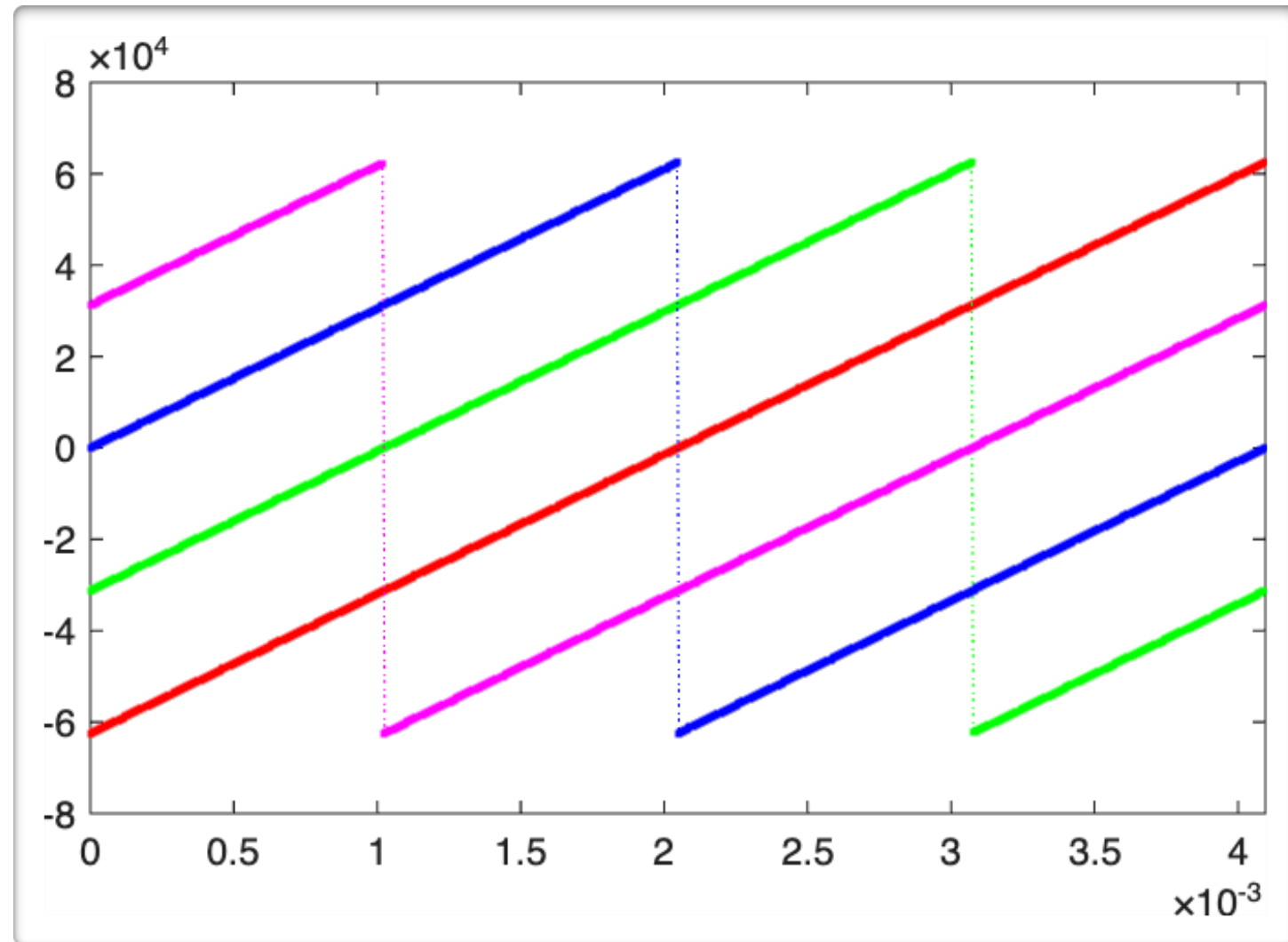

frequency plane modulated symbols

SF = 9, BW = 125 kHz
 $T_s = 4.096$ ms

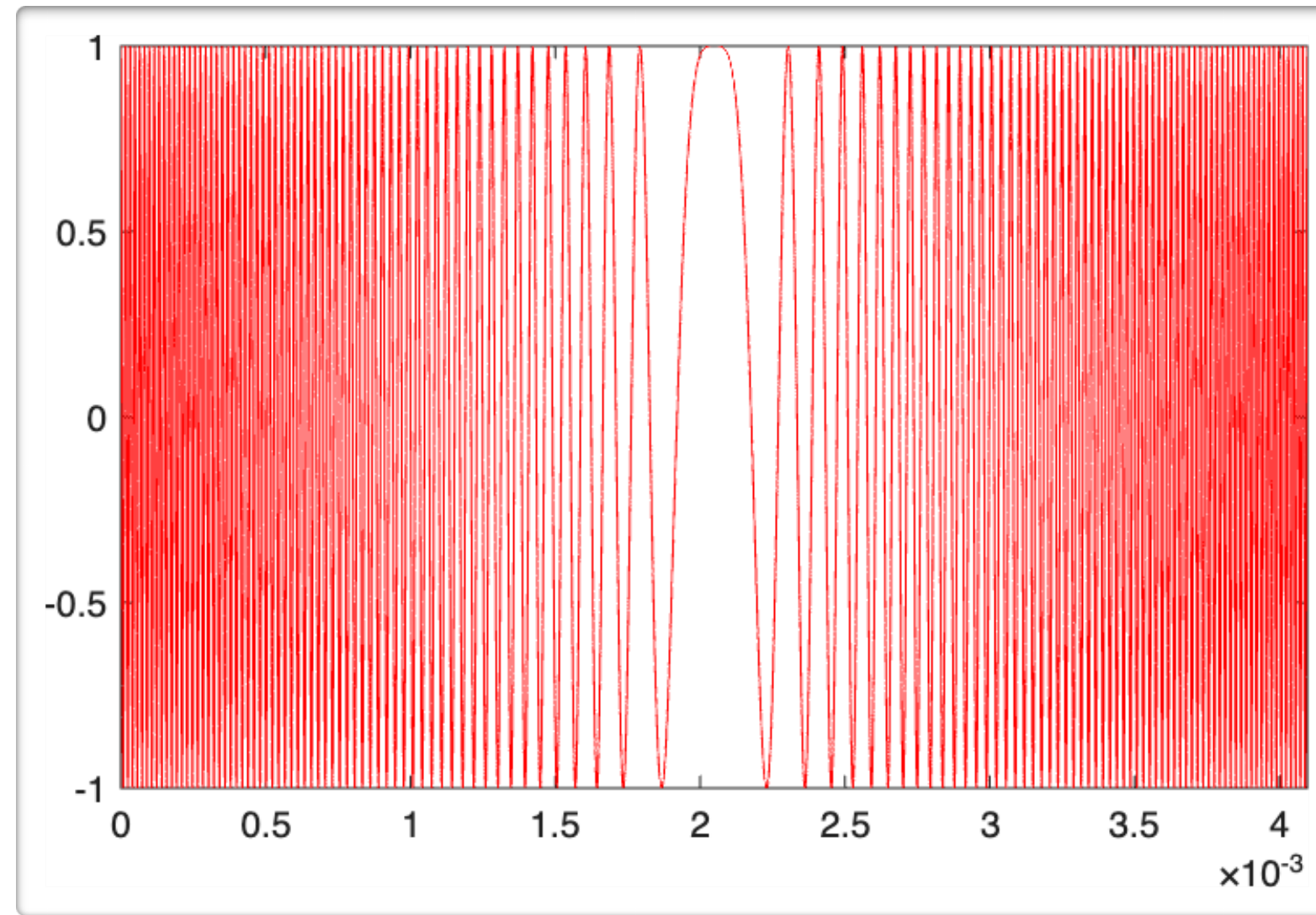

symbol #0

symbol #128

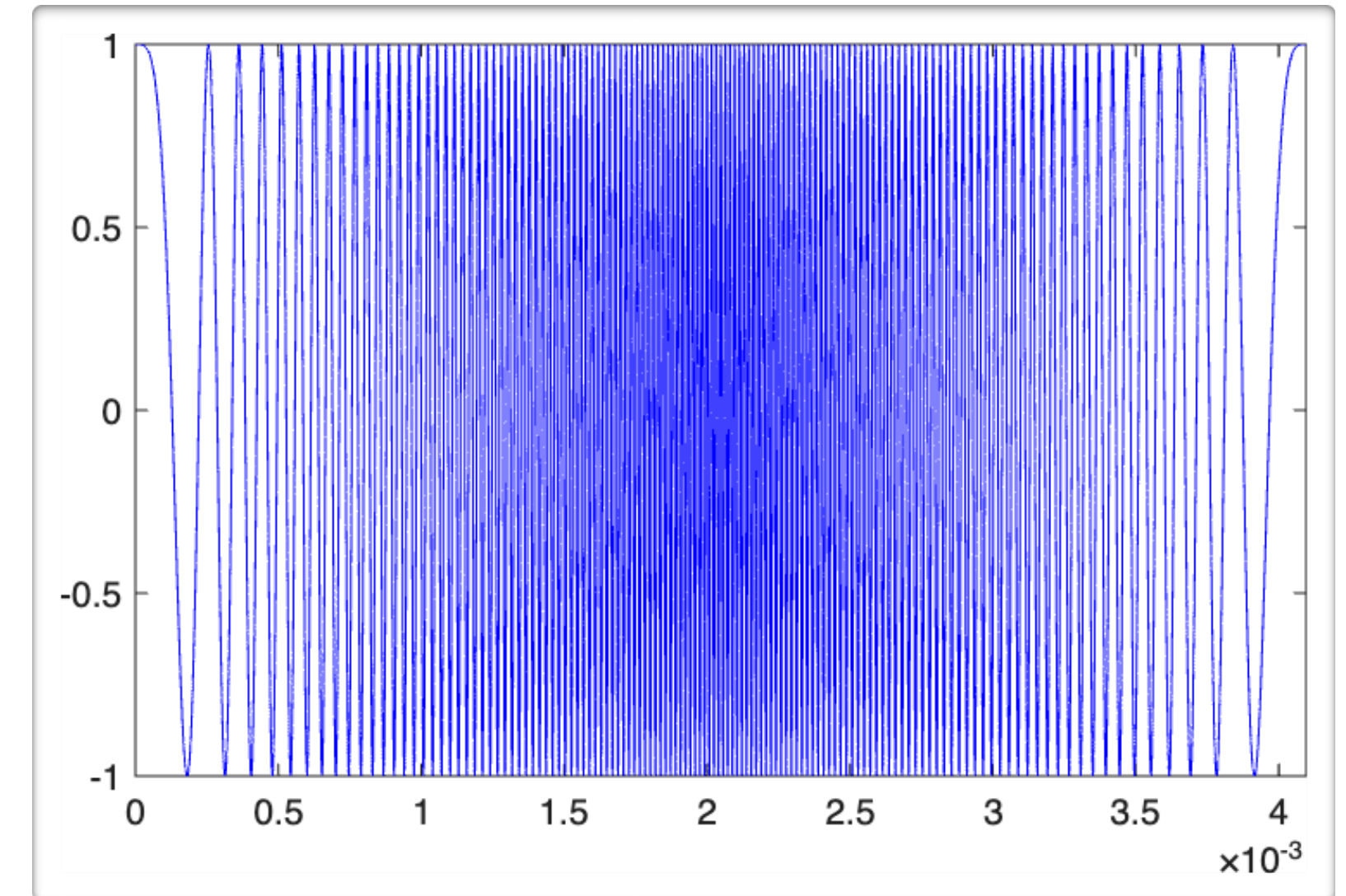

symbol #256

symbol #384

in-phase signal plane

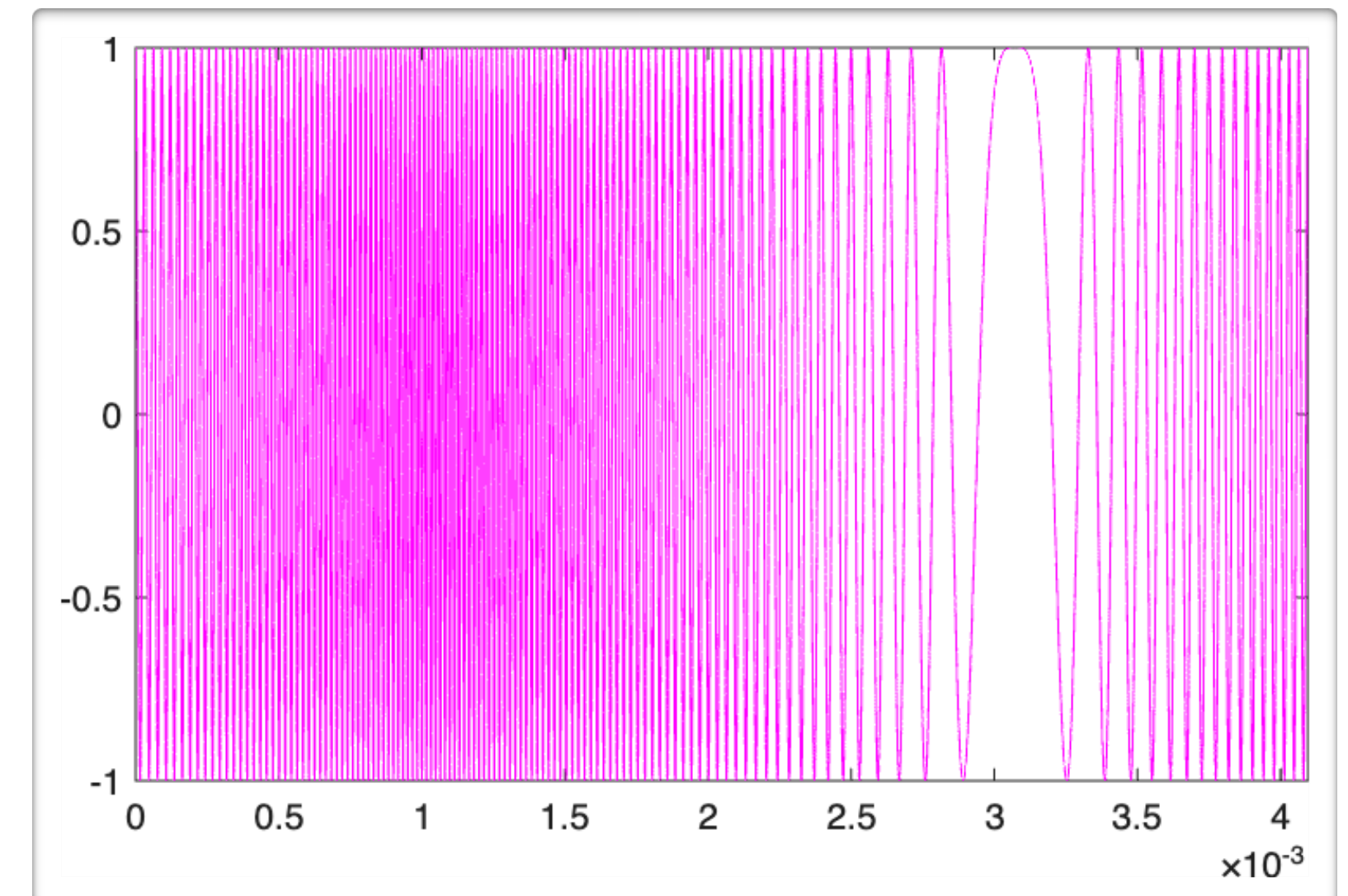
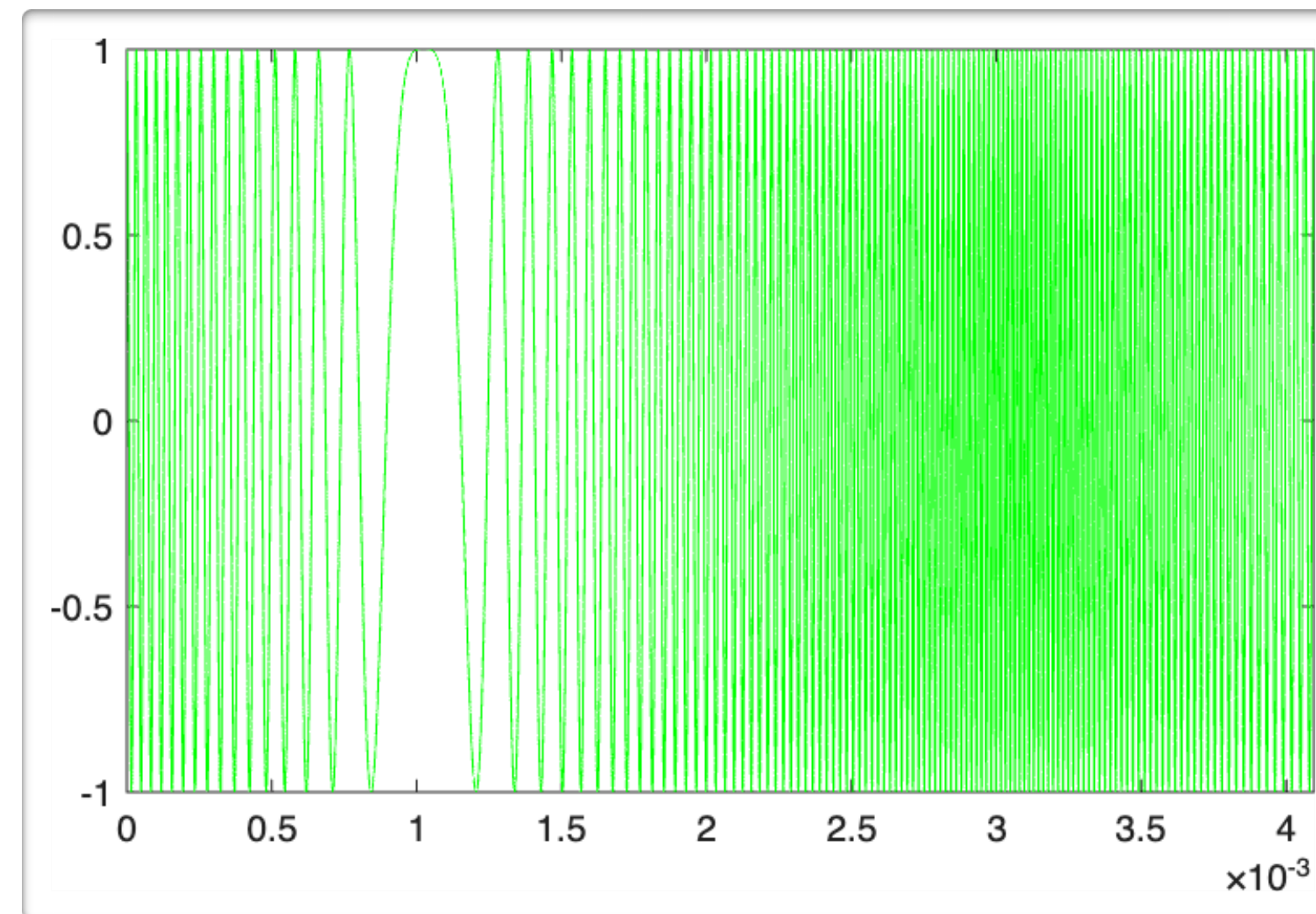

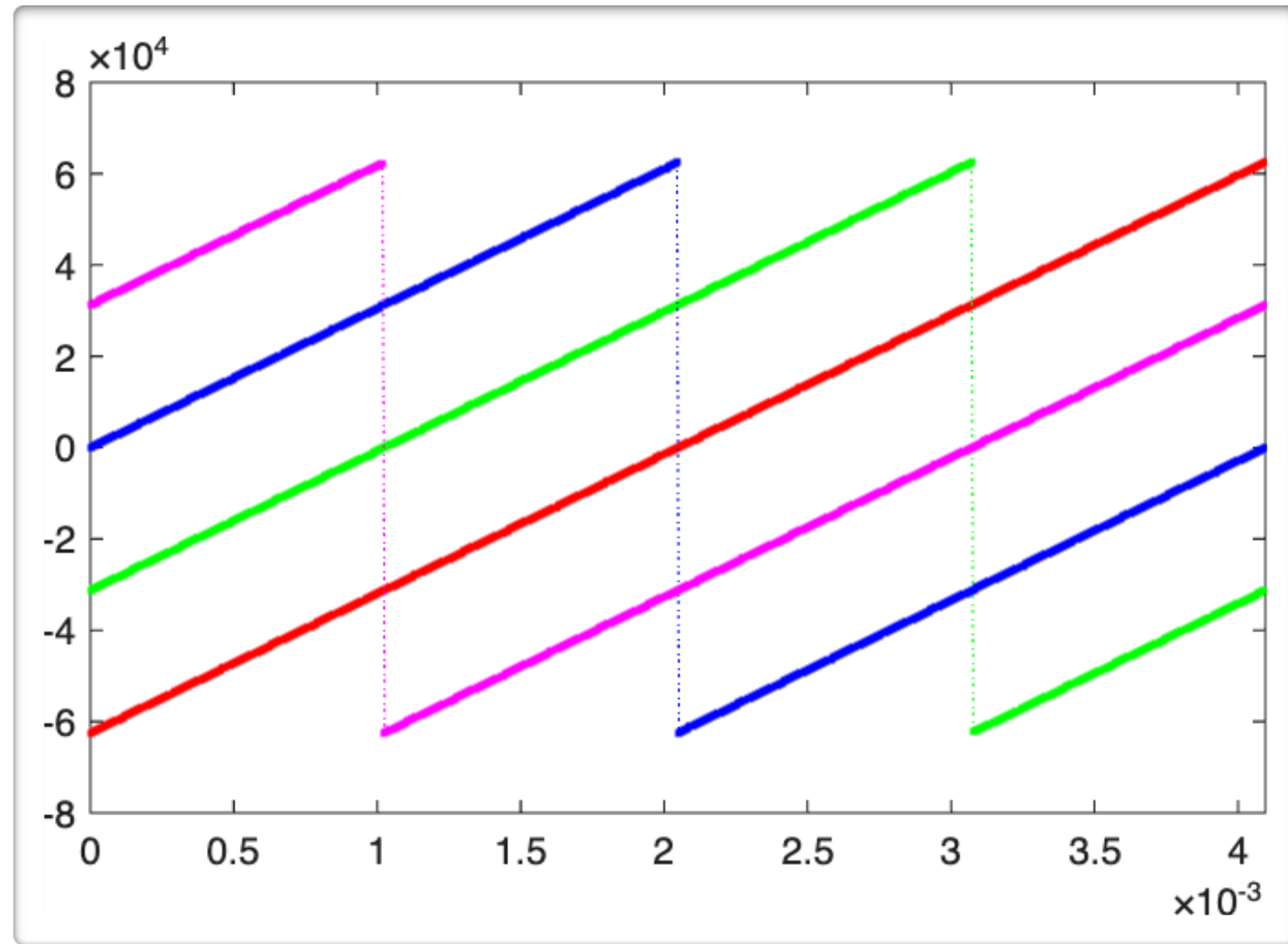

frequency plane modulated symbols

SF = 9, BW = 125 kHz
 $T_s = 4.096$ ms

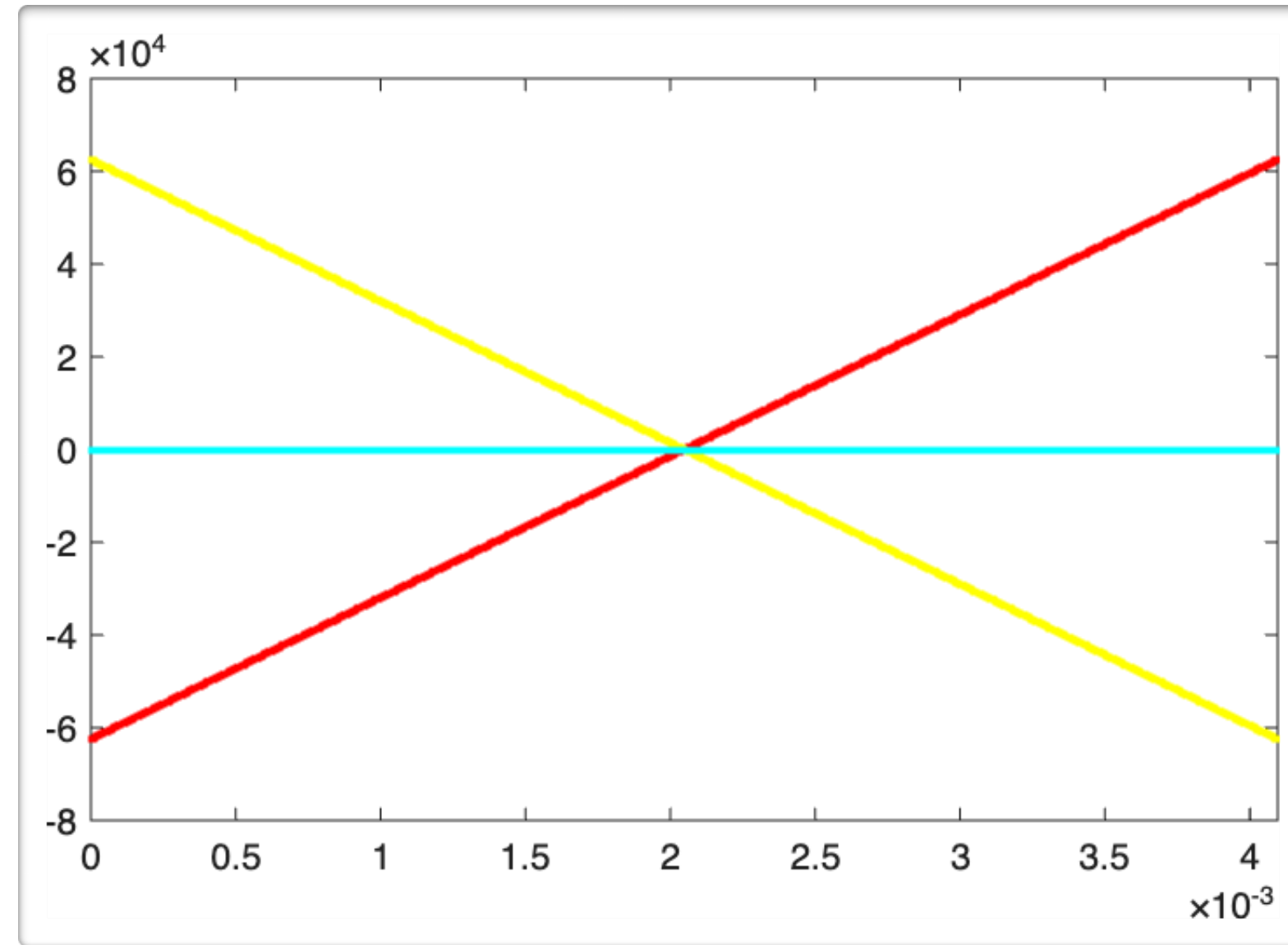

symbol #0
 symbol #128

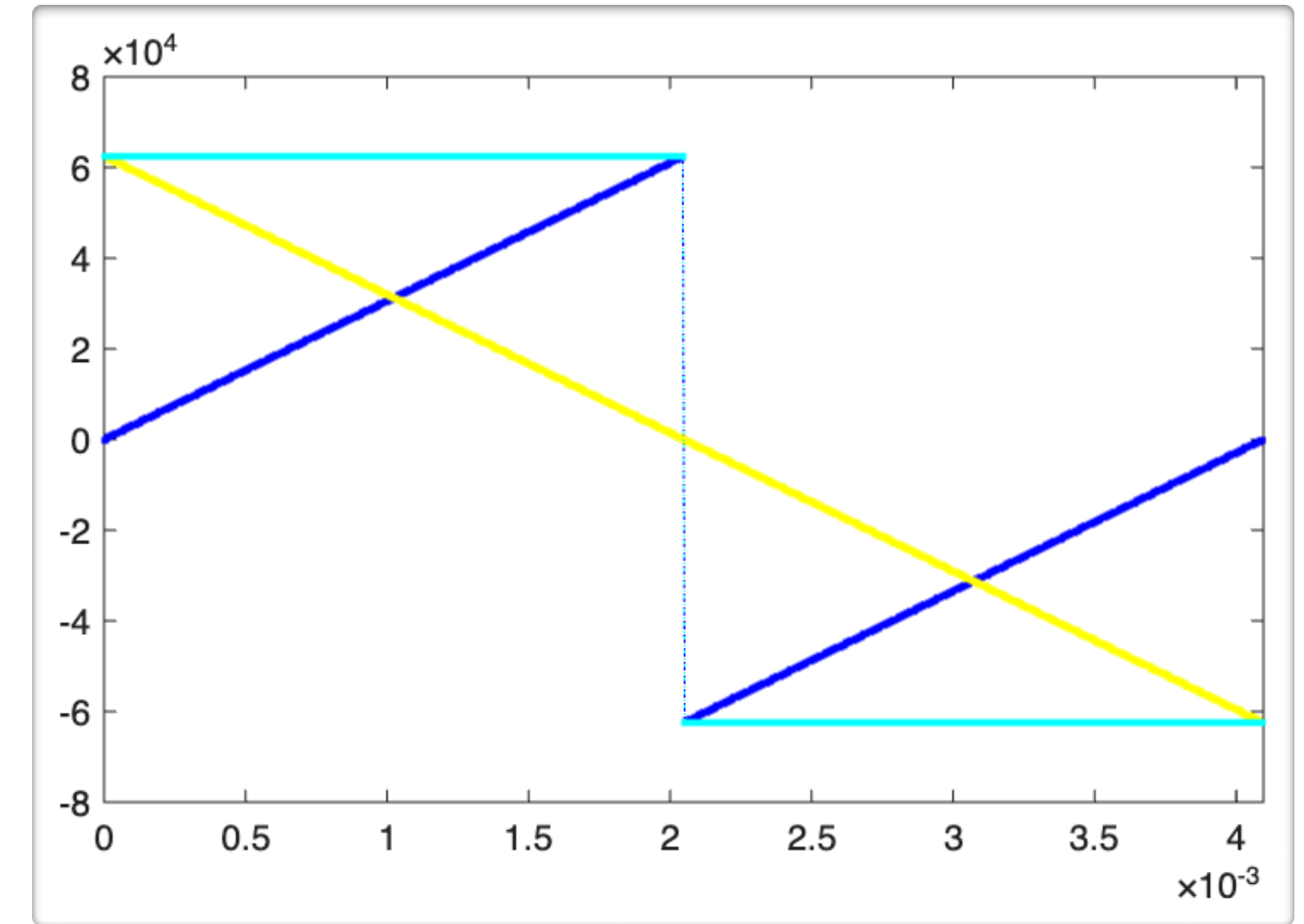

symbol #256
 symbol #384

frequency plane dechirping

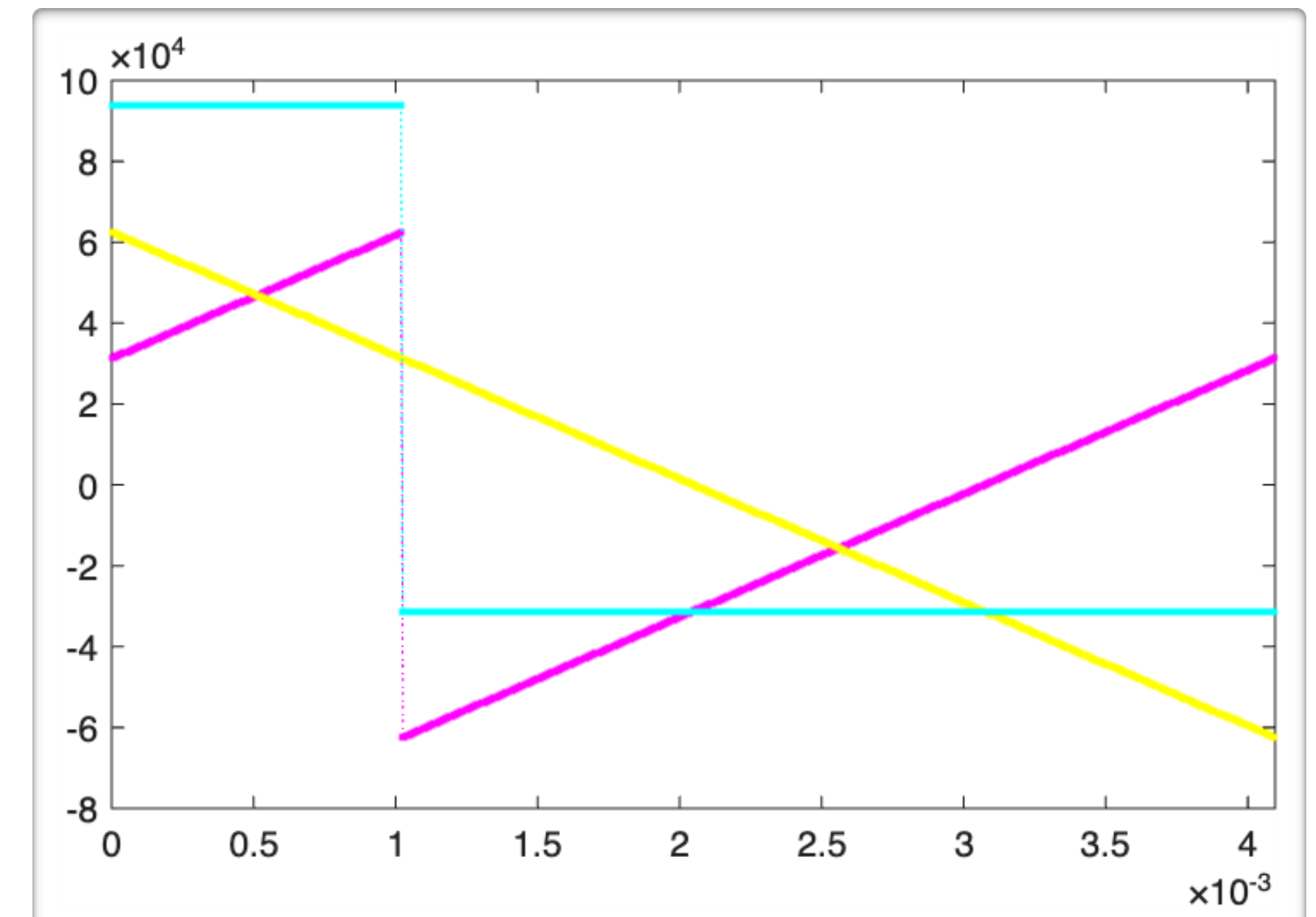
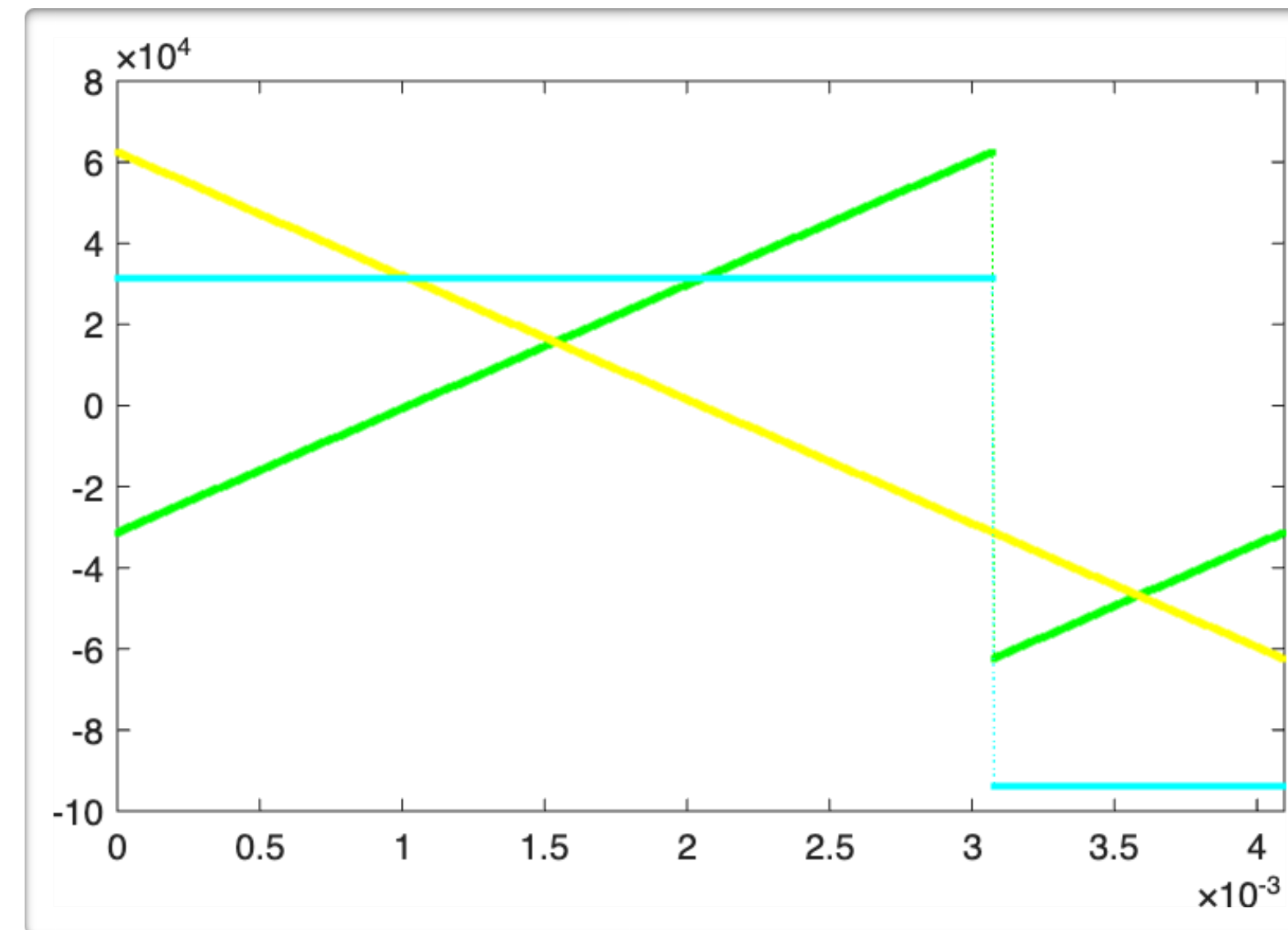

discrete time signal plane dechirping (BW sample rate gives 2^{SF} samples)

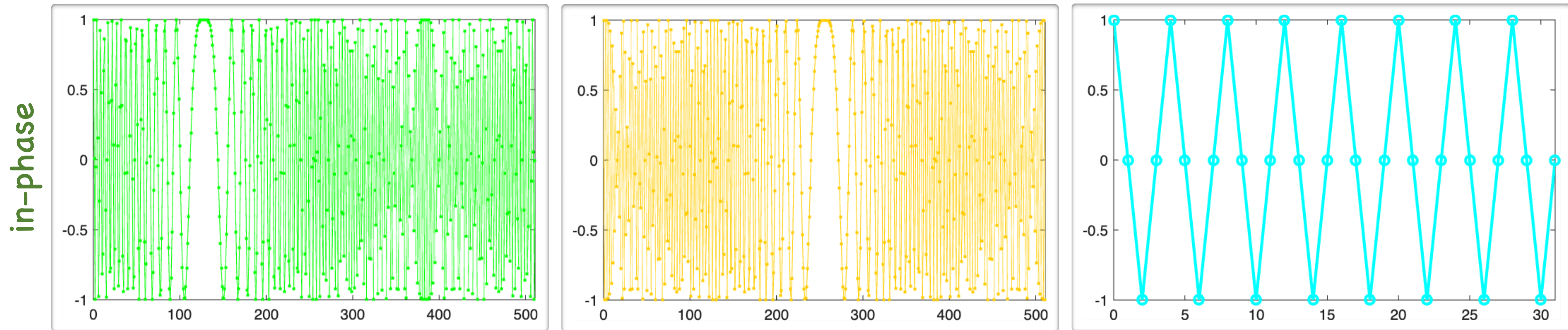

upchirp symbol #128

x basal downchirp

= dechirped #128 (zoom)

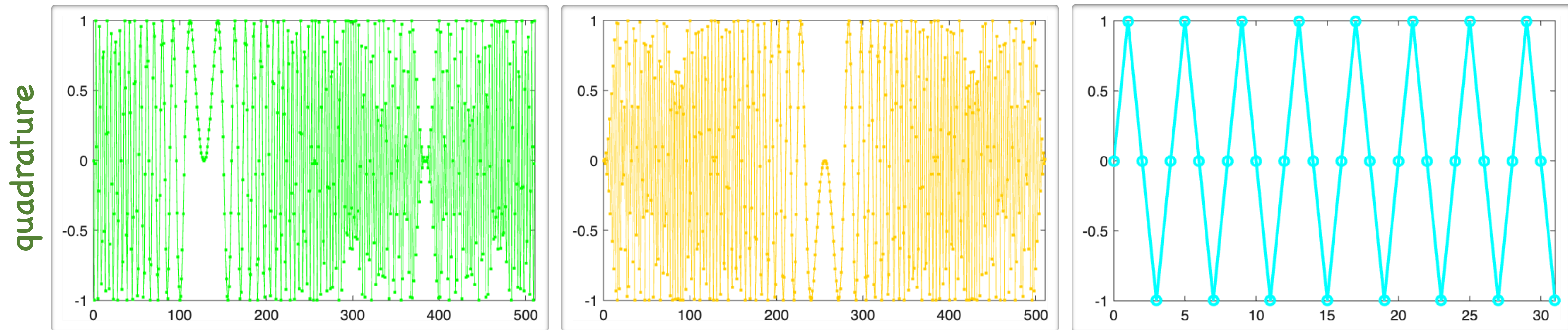

BW = 125 kHz, $1/BW = 8 \mu s$, SF = 9, $2^{SF} = 512$

complex multiplication rules shall be applied: $(a + ib) \times (c + id) = (ac - bd) + i(ad + bc)$

final step: DFT-based decoding

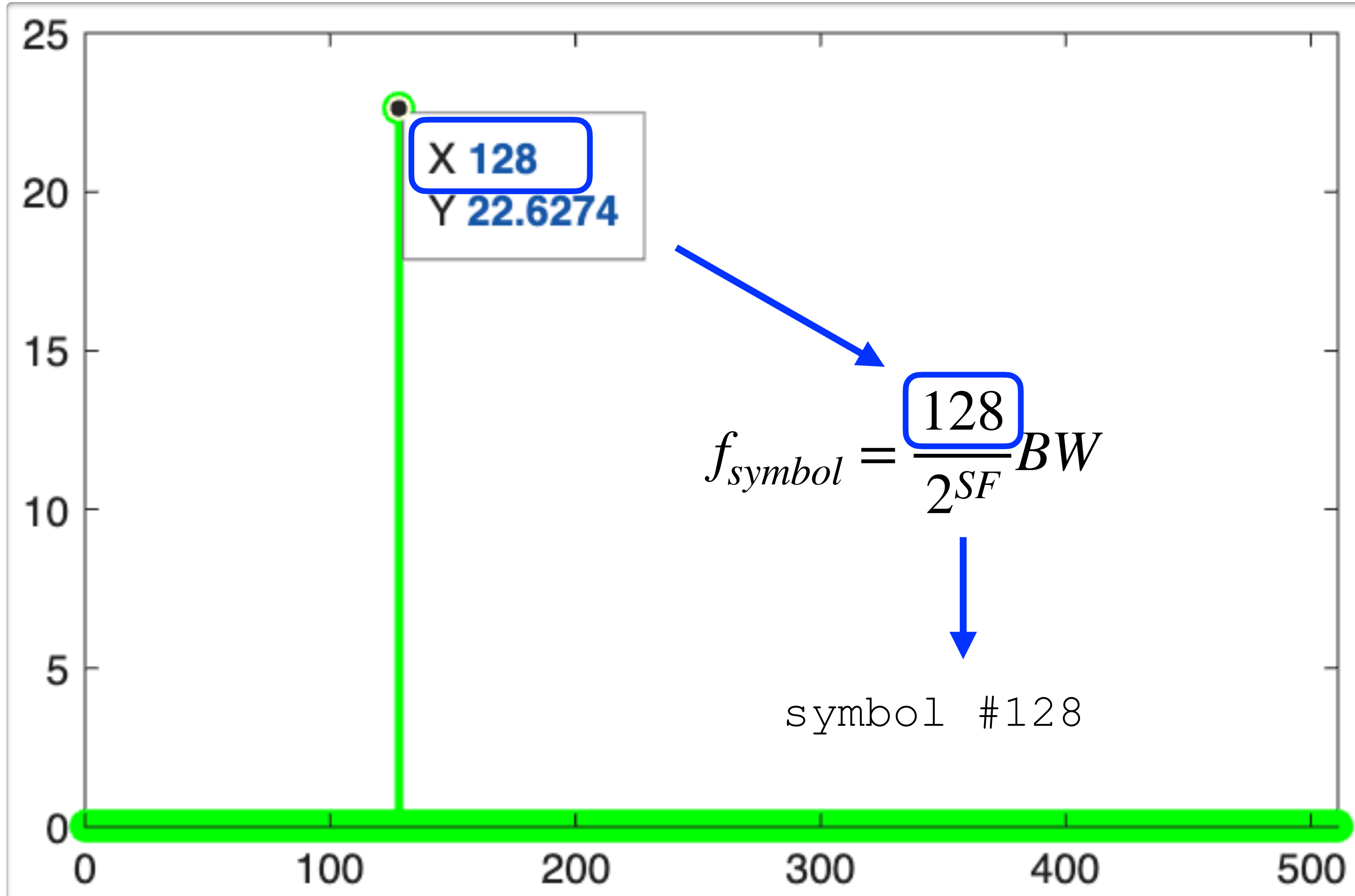

SF = 9
 $2^{SF} = 512$
BW = 125 kHz

What if we did not dechirp? We get white noise spectrum instead..

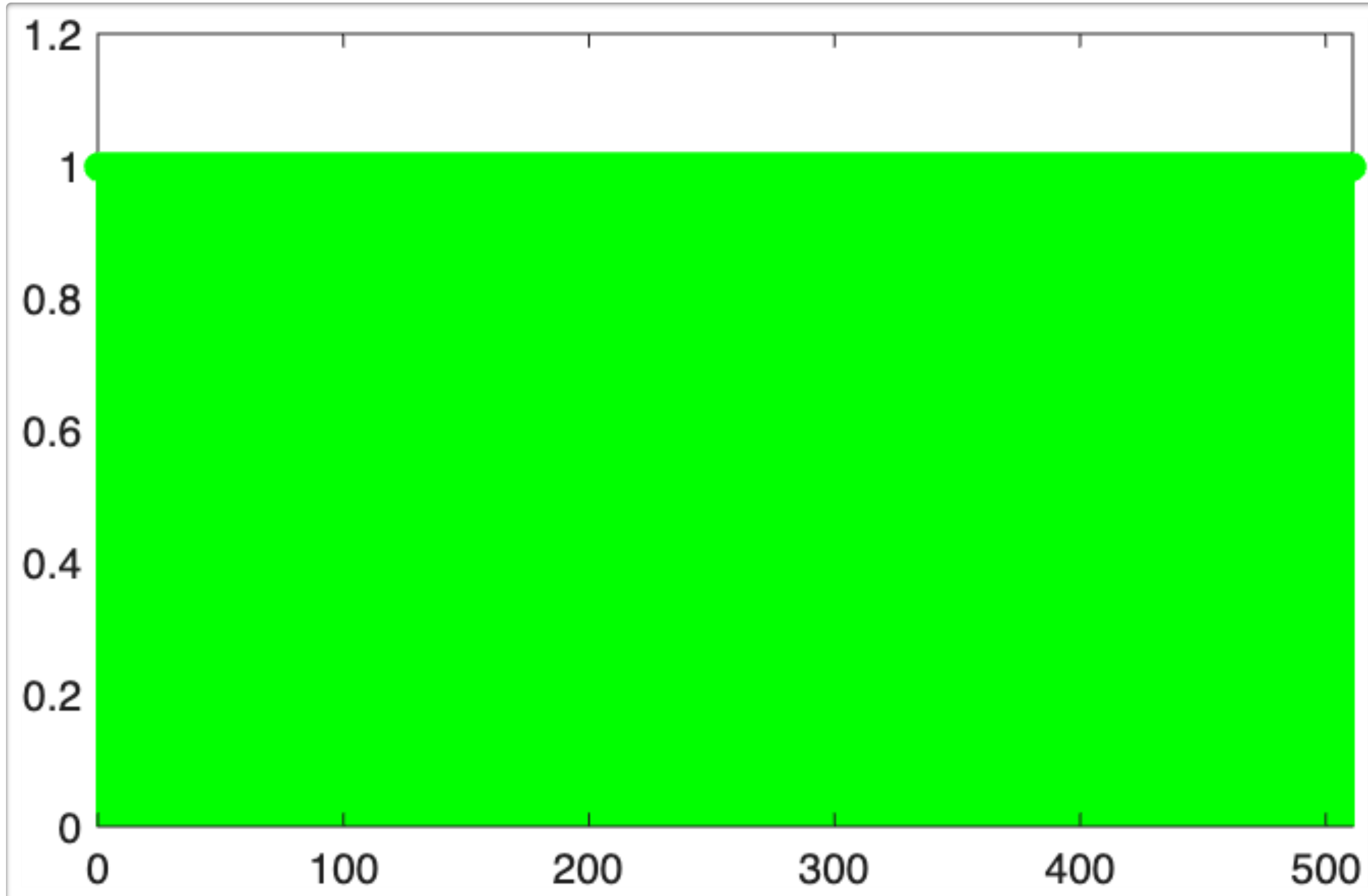

BW = 125 kHz
SF = 9
 $2^{SF} = 512$

Chirp period $T_s = 2^{SF} / BW$ [ms]

SF	5	6	7	8	9	10	11	12
BW [kHz]								
7.81	4.0973	8.1946	16.389	32.778	65.557	131.11	262.23	524.46
10.42	3.071	6.142	12.284	24.568	49.136	98.273	196.55	393.09
15.63	2.0473	4.0947	8.1894	16.379	32.758	65.515	131.03	262.06
20.83	1.5362	3.0725	6.145	12.29	24.58	49.16	98.32	196.64
31.25	1.024	2.048	4.096	8.192	16.384	32.768	65.536	131.07
41.67	0.76794	1.5359	3.0718	6.1435	12.287	24.574	49.148	98.296
62.5	0.512	1.024	2.048	4.096	8.192	16.384	32.768	65.536
125	0.256	0.512	1.024	2.048	4.096	8.192	16.384	32.768
250	0.128	0.256	0.512	1.024	2.048	4.096	8.192	16.384
500	0.064	0.128	0.256	0.512	1.024	2.048	4.096	8.192

MeshCore CZ

//\ medium fast

//\ long fast

$$\text{Raw bit rate } R_b = \text{SF}/T_s = (\text{SF}/2^{\text{SF}}) * \text{BW} \text{ [kbps]}$$

SF	5	6	7	8	9	10	11	12
BW [kHz]								
7.81	1.2203	0.73219	0.42711	0.24406	0.13729	0.07627	0.041948	0.022881
10.42	1.6281	0.97688	0.56984	0.32562	0.18316	0.10176	0.055967	0.030527
15.63	2.4422	1.4653	0.85477	0.48844	0.27475	0.15264	0.08395	0.045791
20.83	3.2547	1.9528	1.1391	0.65094	0.36615	0.20342	0.11188	0.061025
31.25	4.8828	2.9297	1.709	0.97656	0.54932	0.30518	0.16785	0.091553
41.67	6.5109	3.9066	2.2788	1.3022	0.73248	0.40693	0.22381	0.12208
62.5	9.7656	5.8594	3.418	1.9531	1.0986	0.61035	0.33569	0.18311
125	19.531	11.719	6.8359	3.9062	2.1973	1.2207	0.67139	0.36621
250	39.062	23.438	13.672	7.8125	4.3945	2.4414	1.3428	0.73242
500	78.125	46.875	27.344	15.625	8.7891	4.8828	2.6855	1.4648

-- code rate omitted

MeshCore CZ

//\ medium fast

//\ long fast

BW [kHz]
7.81
10.42
15.63
20.83
31.25
41.67
62.5
125
250
500

$$\text{Chip rate } R_c = \frac{2^{SF}}{T_s} = BW$$

- rather a pseudo quantity, since this was possibly a design axiom to allow for DSSS-like processing gain estimation (rule of thumb)
- there is no chipping sequence per se with CSS (Chirp Spread Spectrum)
- perhaps, we could consider baseband discrete-time samples as "chips"
- this axiom then gives T_s definition as used before

$$\text{Processing gain PG} = 10 \cdot \text{Log} [R_c / R_b] = 10 \cdot \text{Log} [(2^{\text{SF}}) / \text{SF}]$$

SF	5	6	7	8	9	10	11	12
PG [dB]	8.0618	10.28	12.621	15.051	17.55	20.103	22.699	25.332
SX126x typical min LoRa demodulator SNR [dB]	-2.5	-5	-7.5	-10	-12.5	-15	-17.5	-20

MeshCore CZ //\ medium fast //\ long fast

$$SNR = 10 \cdot \log_{10} \frac{\text{signal}_{pwr}}{\text{noise}_{pwr}} \text{ [dB]}$$



SX1261/2



SX1261/2 Datasheet

Long Range, Low Power, sub-GHz RF Transceiver

- LoRa IP generation: 2
- Freq: 150 - 960 MHz
- Link budget: 170 dB
- Rx current max: 4.6 mA
- Sensitivity max: -148 dBm
- Tx power max: 22 dBm
- SF: 5 - 12
- BW: 7.8 - 500 kHz

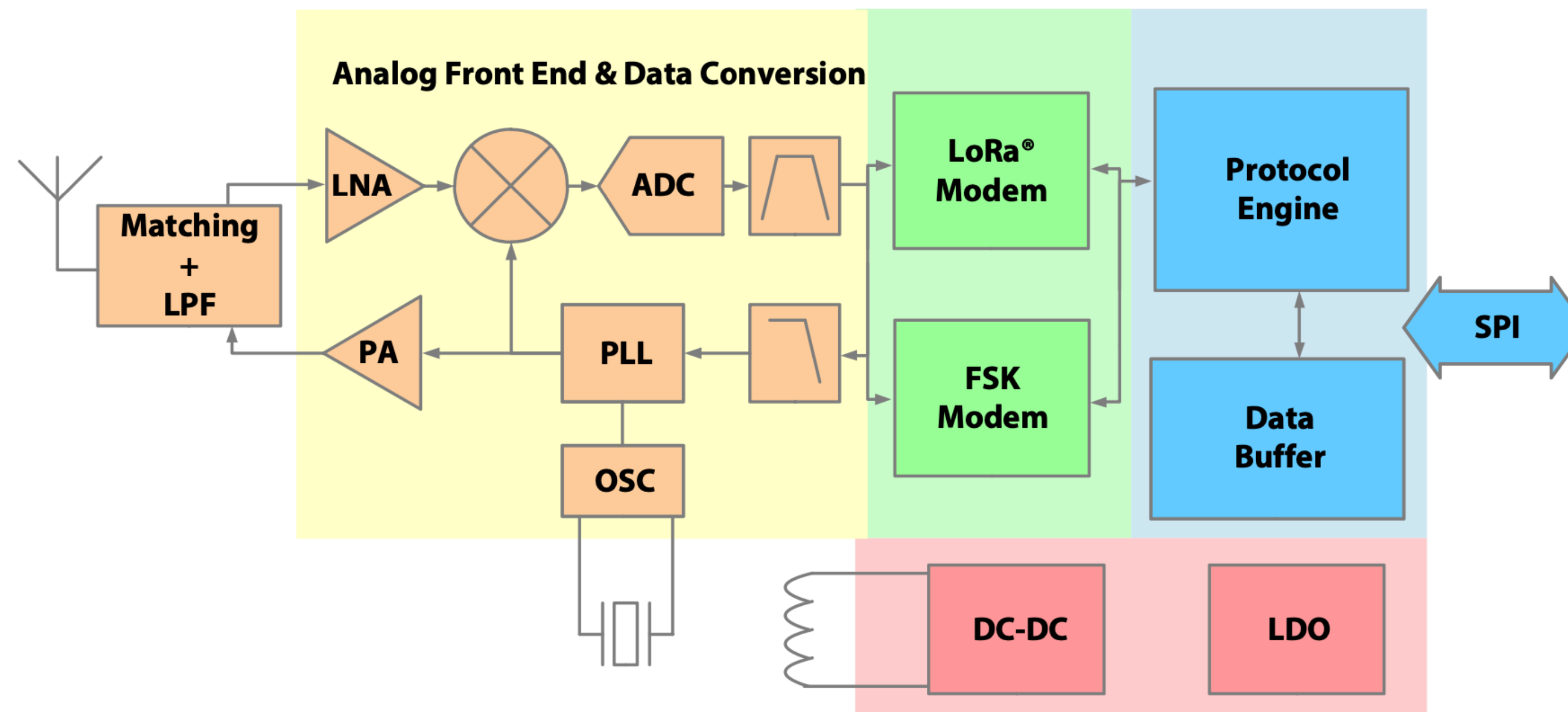

Figure A: SX1261/2 Block Diagram

LoRa Packet Structure

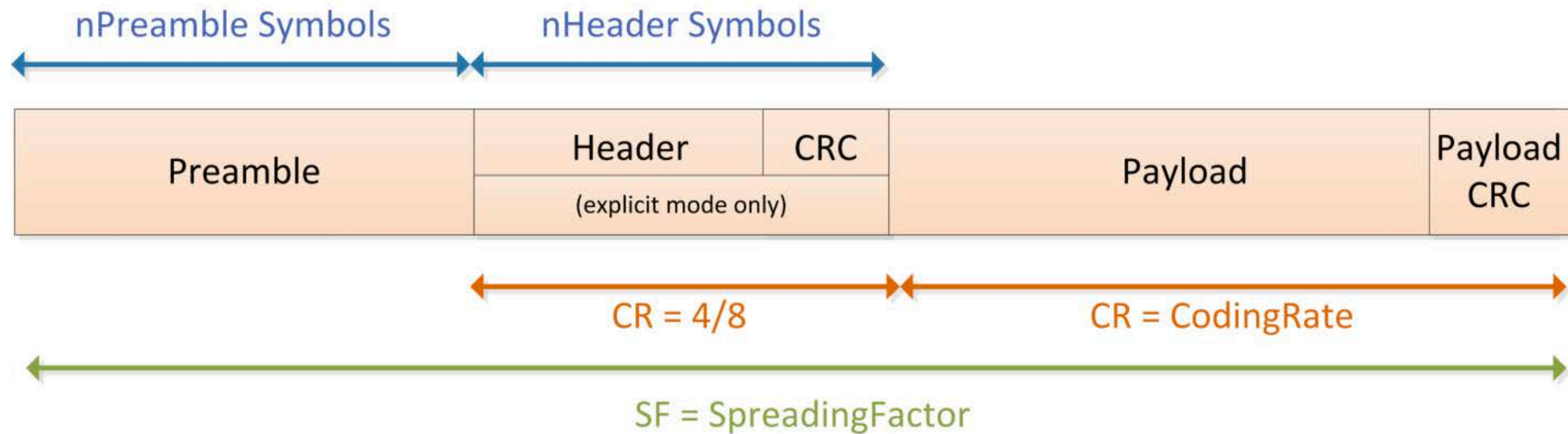
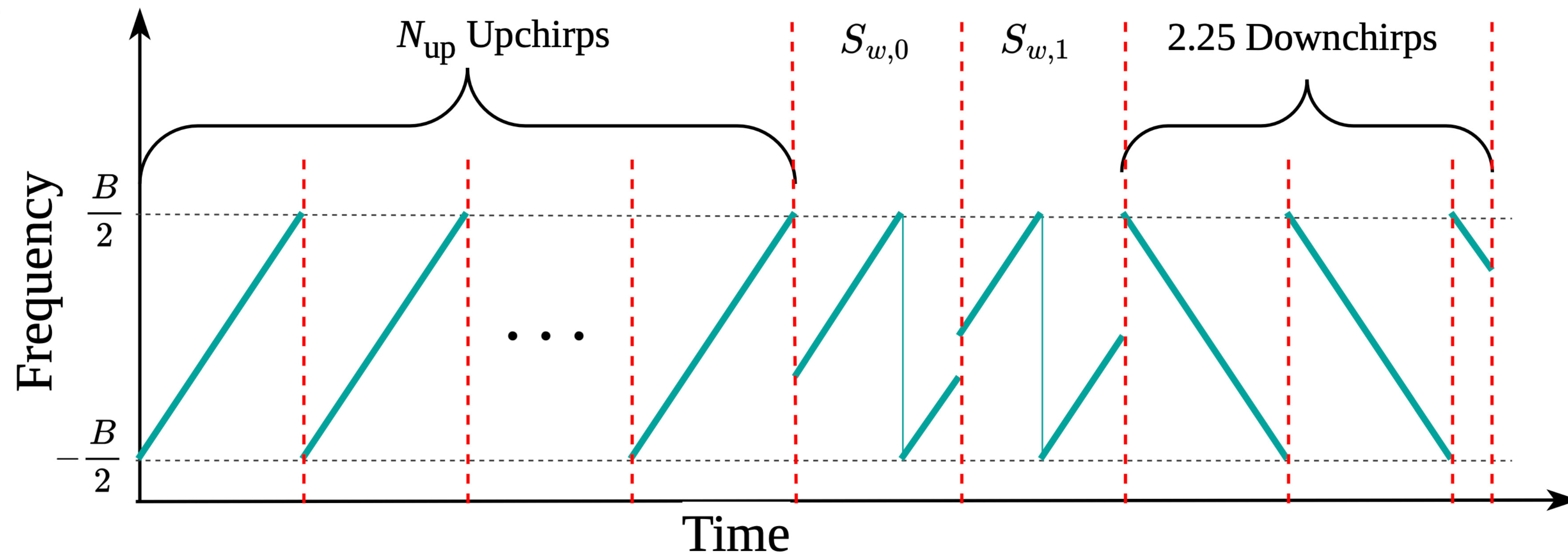

Figure 6-2: LoRa Packet Format

LoRa Preamble with Sync Word (Network Identifier)



Sync word:

0x34 ~ LoRaWAN

0x2B ~ Meshtastic

0x12 ~ private / Meshcore

N_{up} :

16 ~ Meshtastic

Figure 6. Spectrogram of the preamble of a LoRa frame

-- Tapparel, J. and Burg, A.: *Design and Implementation of LoRa Physical Layer in GNU Radio*, 14th GNU Radio Conference, 2024

-- <https://meshtastic.org/docs/overview/mesh-algo/>

Example Network Header - Meshtastic

Offset	Length	Type	Usage
0x00	4 bytes	Integer	Packet Header: Destination. The destination's unique NodeID. <code>0xFFFFFFFF</code> for broadcast. Little-endian.
0x04	4 bytes	Integer	Packet Header: Sender. The sender's unique NodeID. Little-endian.
0x08	4 bytes	Integer	Packet Header: The sending node's unique packet ID for this packet. Little-endian.
0x0C	1 byte	Bits	Packet Header: Flags. See the header flags for usage.
0x0D	1 byte	Bits	Packet Header: Channel hash. Used as hint for decryption for the receiver.
0x0E	1 byte	Bytes	Packet Header: Next-hop used for relaying.
0x0F	1 byte	Bytes	Packet Header: Relay node of the current transmission.
0x10	Max. 237 bytes (excl. protobuf overhead)	Bytes	Actual packet data. Unused bytes are not transmitted.

Packet Header Flags

Index	# of Bits	Usage
0	3	HopLimit (see note in Layer 3)
3	1	WantAck
4	1	ViaMQTT (packet came via MQTT)
5	3	HopStart (original HopLimit)

SRD ~ Short Range Devices (EU)



ERC Recommendation 70-03

Relating to the use of Short Range Devices (SRD)

approved 1997 (Tromsø)

Subsequent amendments 14 February 2025

Please Note

Implementation Status page 46

Frequency Band		Power / Magnetic Field	Spectrum access and mitigation requirements	Modulation / occupied bandwidth	ECC/ERC Deliverable	ETSI ENs	Notes
f3	169.4875-169.5875 MHz	10 mW e.r.p.	≤ 0.001% duty cycle except for 00:00 h to 06:00 h local time where the duty cycle limit is ≤ 0.1%	Not specified	ECC/DEC/(05)02		The frequency band is also identified in Annex 10
f4	169.5875-169.8125 MHz	10 mW e.r.p.	≤ 0.1% duty cycle	Not specified	ECC/DEC/(05)02		
g1	433.05-434.79 MHz	10 mW e.r.p.	≤ 10% duty cycle	Not specified			
g2	433.05-434.79 MHz	1 mW e.r.p.	No requirement	Not specified			
g3	434.04-434.79 MHz	10 mW e.r.p.	No requirement	≤ 25 kHz			
h0	862-863 MHz	25 mW e.r.p.	≤ 0.1% duty cycle	≤ 350 kHz			
h1.0	863-870 MHz (note 2)	25 mW e.r.p.	≤ 0.1% duty cycle (note 1)	≤ 100 kHz for 47 or more hop channels			For FHSS. Parts of the frequency band are also identified in Annexes 2, 3, 10 and 11
h1.2	863-870 MHz (note 2)	25 mW e.r.p. -4.5 dBm/100 kHz e.r.p.	≤ 0.1% duty cycle or LBT+AFA	Not specified			For Non-FHSS. Parts of the frequency band are also identified in Annexes 2, 3, 10 and 11
h1.3	863-865 MHz	25 mW e.r.p.	≤ 0.1% duty cycle or LBT+AFA	Not specified			The frequency band is also identified in Annexes 3 and 10
h1.4	865-868 MHz	25 mW e.r.p.	≤ 1% duty cycle or LBT+AFA	Not specified			The frequency band is also identified in Annexes 2, 3 and 11
h1.5	868-868.6 MHz	25 mW e.r.p.	≤ 1% duty cycle or LBT+AFA	Not specified			
h1.6	868.7-869.2 MHz	25 mW e.r.p.	≤ 0.1% duty cycle or LBT+AFA	Not specified			
h1.7	869.4-869.65 MHz	500 mW e.r.p.	≤ 10% duty cycle or LBT+AFA	Not specified			
h1.8	869.7-870 MHz	5 mW e.r.p.	No requirement	Not specified			
h1.9	869.7-870 MHz	25 mW e.r.p.	≤ 1% duty cycle or LBT+AFA	Not specified			

// \ Meshtastic EU in 868 MHz band

869.525 MHz

-- <https://meshtastic.org/docs/overview/radio-settings/>

MeshCore CZ in 868 MHz band

869.432 MHz

-- https://meshcore.cz/nastaveni_site_meshcore_cz

LoRa Sniffing

- **Offline - harvest now, decode later**
 - SDR is an obvious option, see GitHub (etc.) for GNU Radio low-level blocks
 - for instance: <https://github.com/rpp0/gr-lora>, https://github.com/tapparelj/gr-lora_sdr
 - we have a plenty of time to get the parameters right - essentially "MATLAB exercise"
- **Online - realtime, as the communication unfolds**
 - tiny time window to estimate the modulator setup
 - still doable if we allow for certain capture lag - assumes the parameters do not vary with time (!)
 - complicates further with possible frequency hopping

Chasing Modulator Parameters

- We need at least **correct SF and BW**
 - **wrong SF** makes the dechirping with Fourier transform decoding fail
 - we would see a noise-like signal
 - **wrong BW** (actually wider) can capture unnecessary noise
 - furthermore, incorrect sampling makes the Nyquist folding frequency tricks fail
- Also a possibly different **base chirp polarity** is then a cherry on the cake
- Seems the **brute force** by parallel running radios is not that bad option
 - *this is probably expensive in realtime, or ... ?*

125kHz LoRa reception with:

- 8 x 8 channels packet detectors
- 8 x SF5-SF12 demodulators
- 8 x SF5-SF10 demodulators

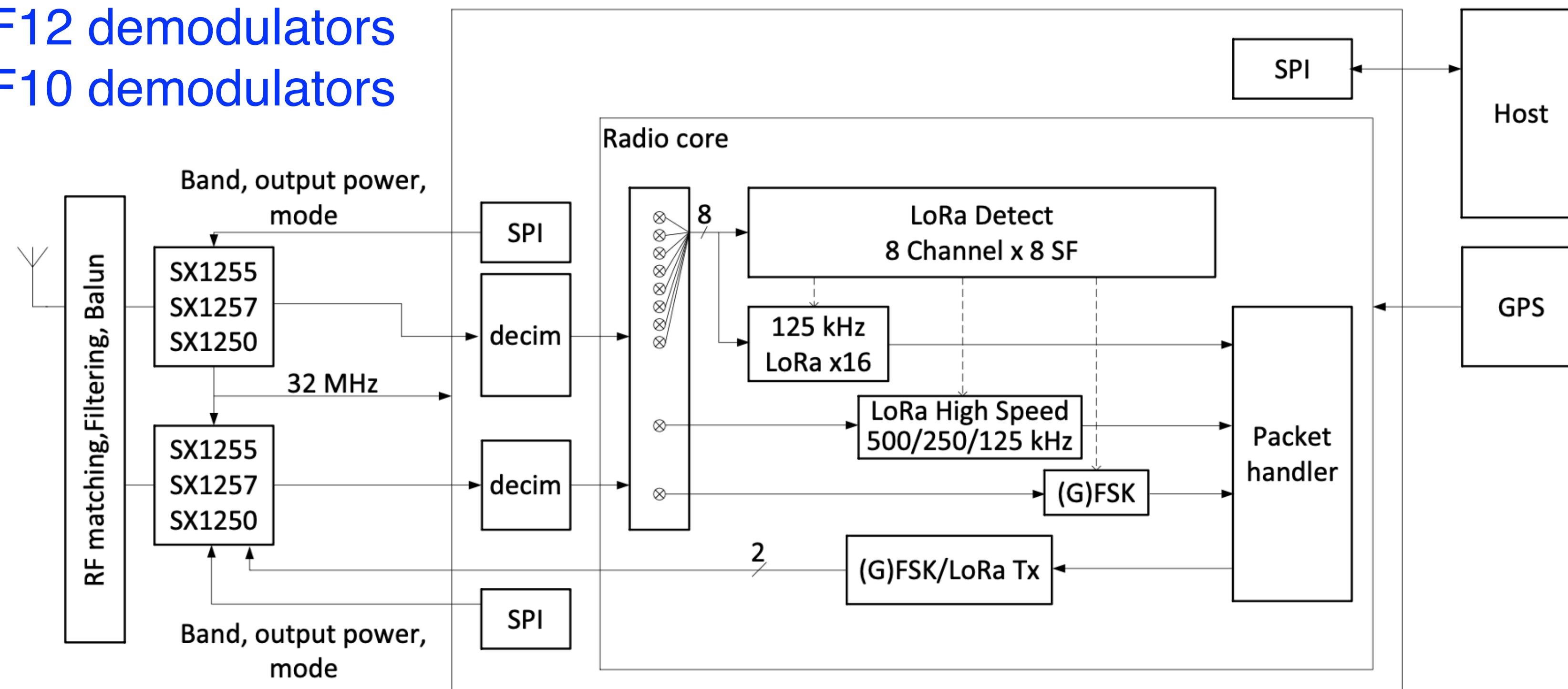

Meshtastic /^ - Easy Way to Practice (with ad hoc mesh topology)

The screenshot shows the Meshtastic website's introduction page. The browser address bar displays `meshtastic.org/docs/introduction/`. The page features a navigation menu on the left with items like 'About', 'Introduction', 'Overview', 'Contributing', 'FAQs', 'Getting Started', 'Configuration', 'Hardware', 'Software', 'Community', 'Development', 'Legal', and 'Glossary of Terms'. The main content area is titled 'Introduction' and contains the following text: 'Meshtastic® is a project that enables you to use inexpensive LoRa radios as a long range off-grid communication platform in areas without existing or reliable communications infrastructure. This project is 100% community driven and open source!'. Below this text is a diagram illustrating an ad hoc mesh topology. The diagram shows a central 'Router' node connected to several 'Client' nodes. The connections are color-coded: green for LoRa, blue for Bluetooth, and grey for WiFi. A legend at the bottom of the diagram identifies these connection types. To the left of the diagram is a smartphone displaying the Meshtastic mobile app interface, showing a 'Primary Channel' and a list of nodes (Node 1: Periodic beacon, Node 3: Node online). To the right is a laptop displaying the Meshtastic command-line interface (CLI) with the following output:

```
meshtastic-cl
[Node 7]: All clear
[Node 1]: Periodic beacon
[Node 3]: Node online
```

Introduction

Meshtastic® is a project that enables you to use inexpensive LoRa radios as a long range off-grid communication platform in areas without existing or reliable communications infrastructure. This project is 100% community driven and open source!

Features

- Long range ([331km record by MartinR7 & alleg](#))
- No phone required for mesh communication



RAK WisMesh Pocket V2

-- <https://store.rakwireless.com/products/wismesh-pocket>

-- <https://hexaspot.com/products/wismesh-pocket-v2-ready-to-use-meshtastic-devicet>

LoRa RF: Semtech SX1262
controller: Nordic nRF52840
display: 1.3" OLED
battery: 3200mAh
supports: LoRa, BLE, GNSS, NFC-A, USB-C*

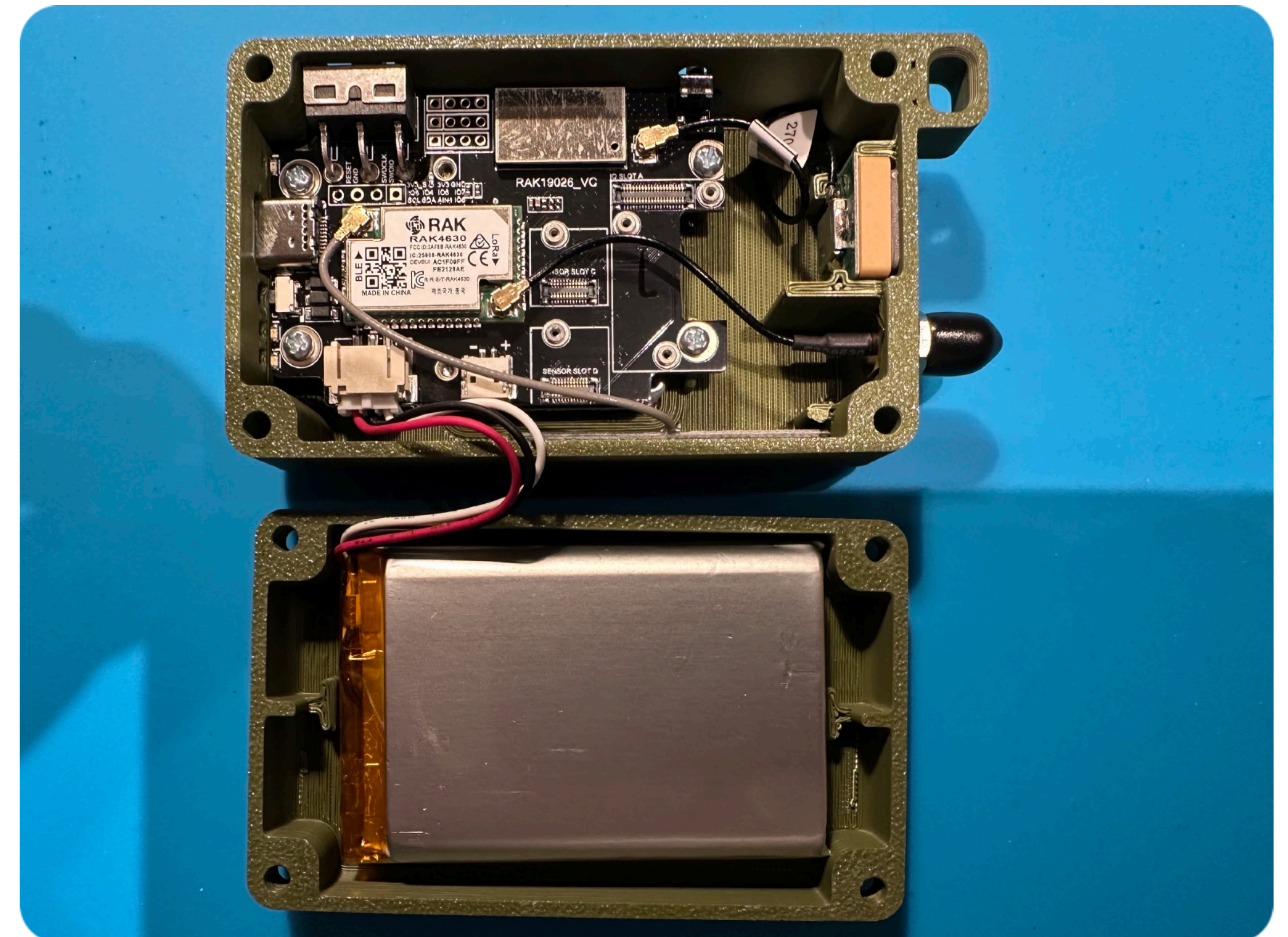

*) rather USB 2.0 via USB-C

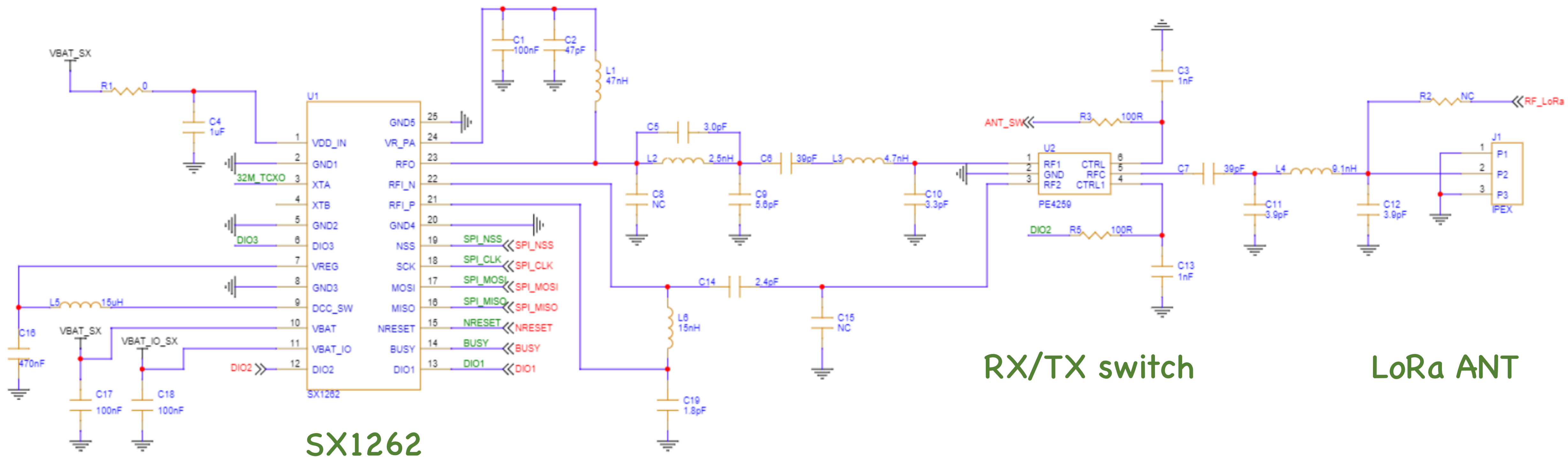

SX1262

RX/TX switch

LoRa ANT

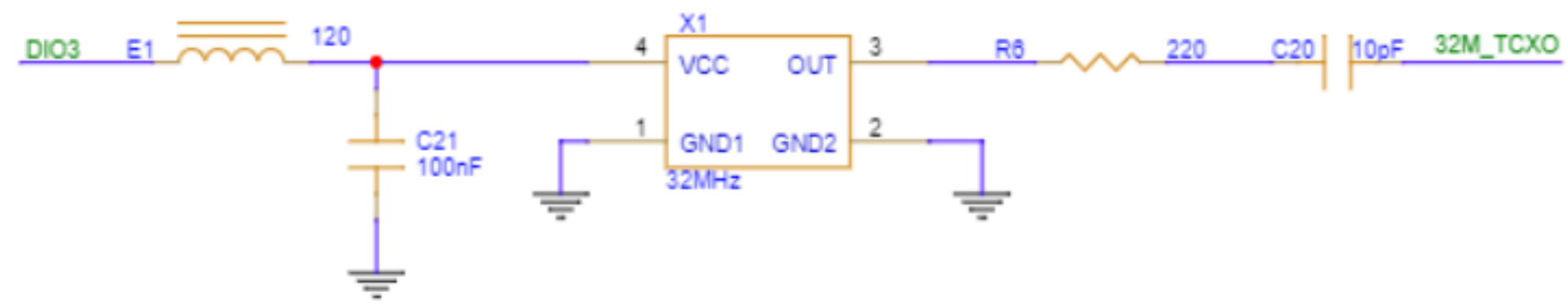

TCXO



PCB pinout

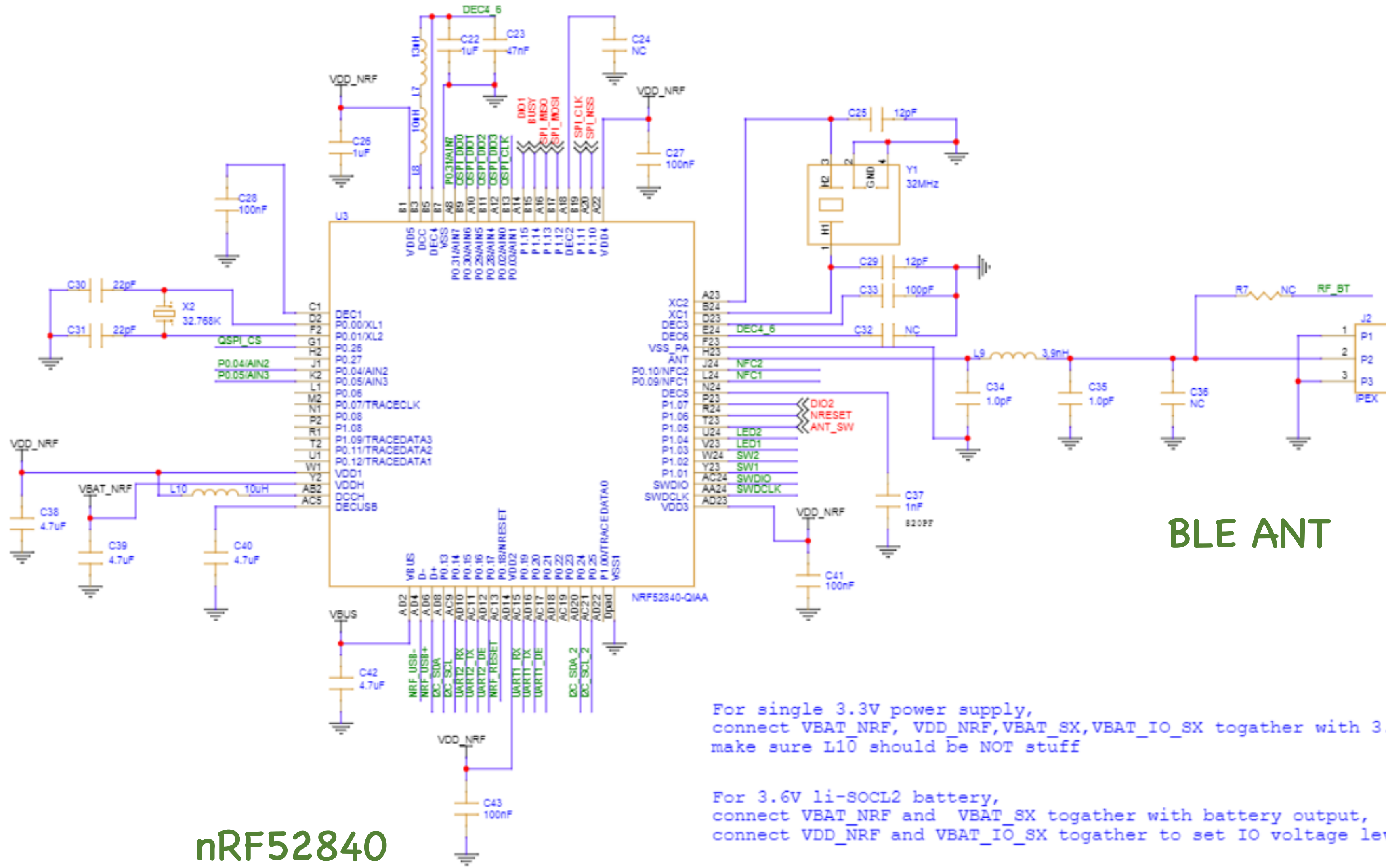

nRF52840

BLE ANT

For single 3.3V power supply, connect VBAT_NRF, VDD_NRF, VBAT_SX, VBAT_IO_SX together with 3.3V power. make sure L10 should be NOT stuff

For 3.6V li-SOCL2 battery, connect VBAT_NRF and VBAT_SX together with battery output, connect VDD_NRF and VBAT_IO_SX together to set IO voltage level.

For 4.2V li-MnO2 battery, connect VBAT_NRF with battery output, should add external DC-DC convert or LDO for VBAT_SX(3.3V) connect VDD_NRF and VBAT_IO_SX together to set IO voltage level.

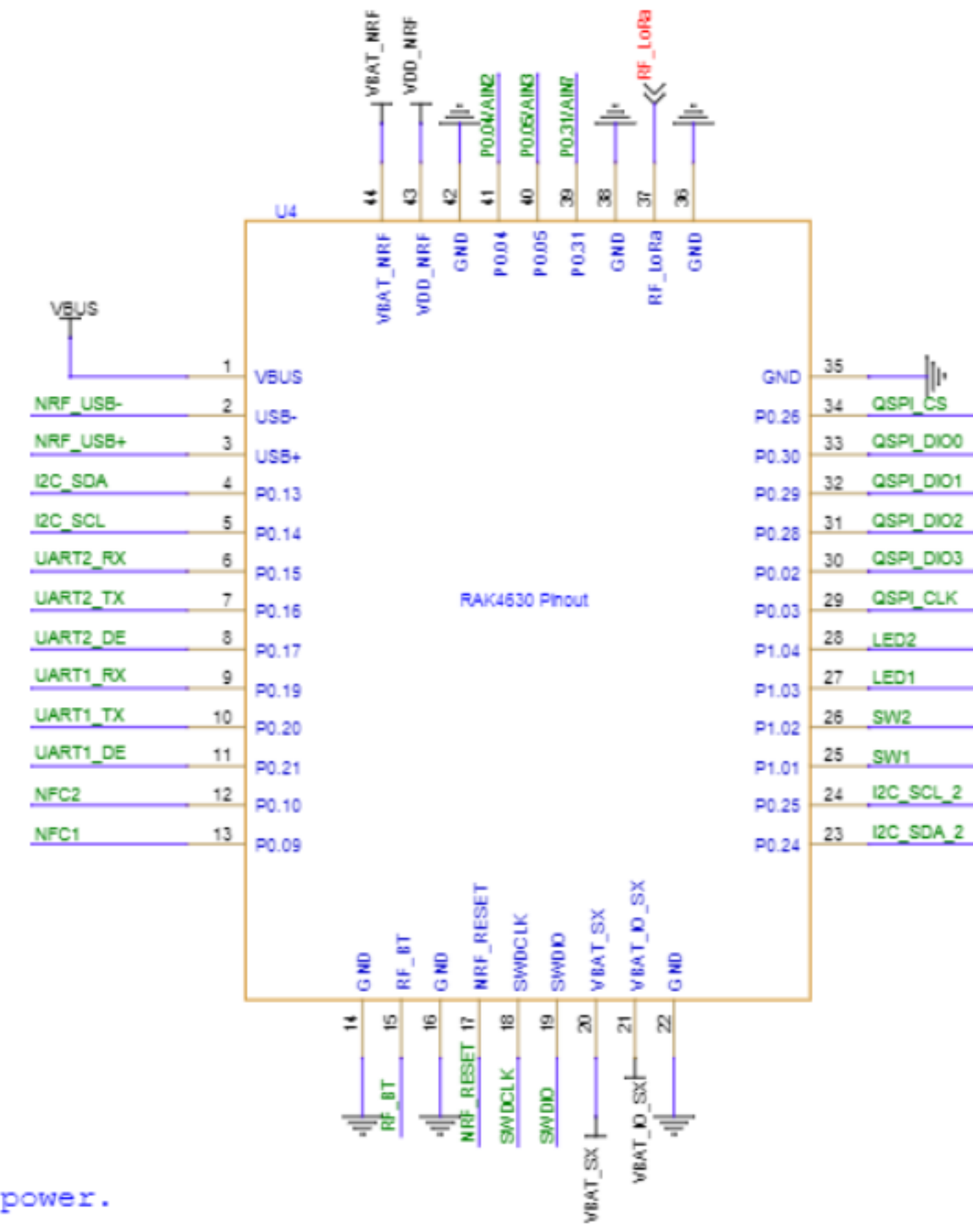

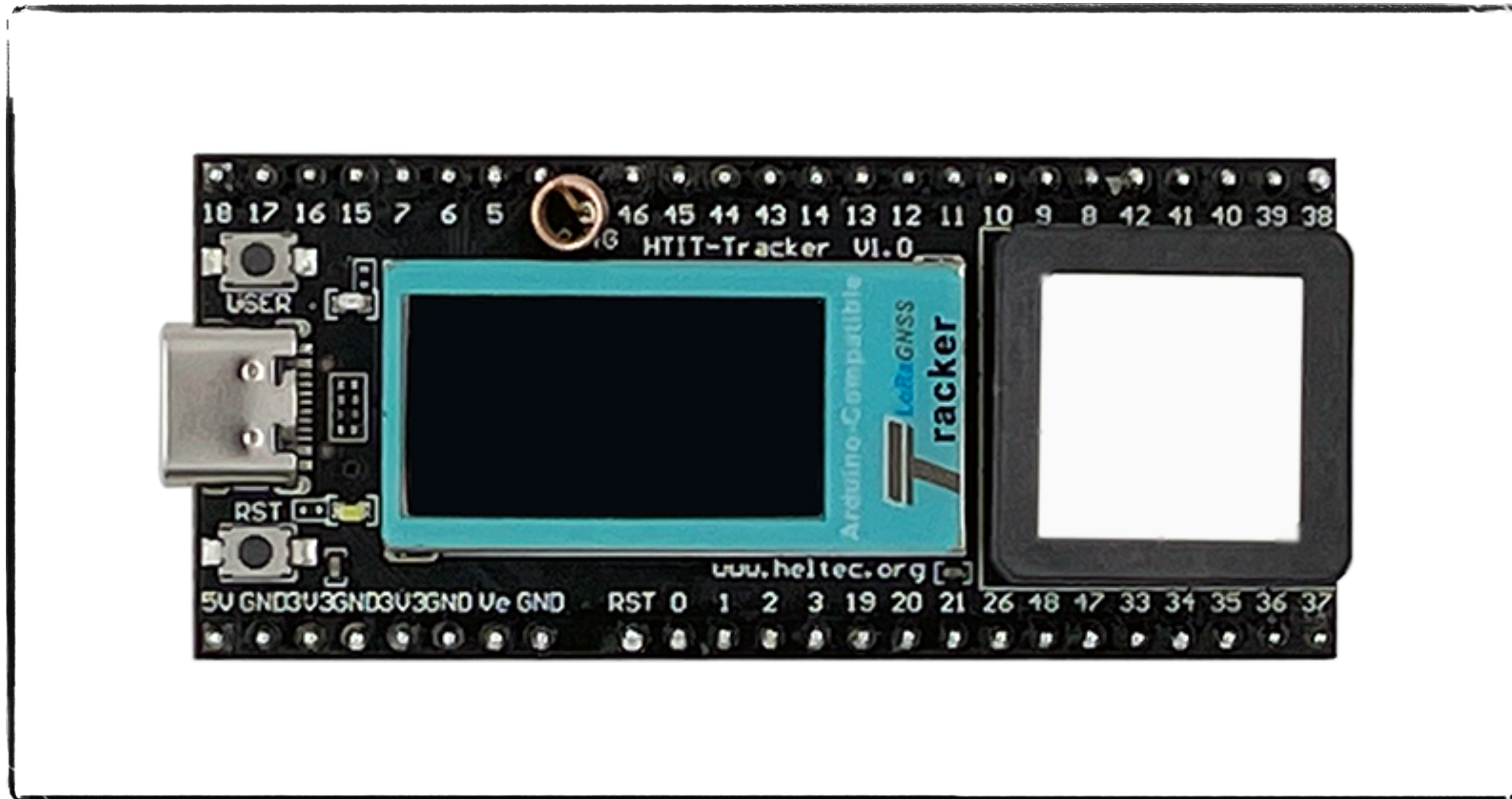

LoRa RF: Semtech SX1262
controller: Espressif ESP32-S3FN8
display: 0.96" TFT
battery: none, 3.7V LiPo ready
supports: LoRa, BLE, WiFi, GNSS, USB-C*

Heltec Wireless Tracker V1.1

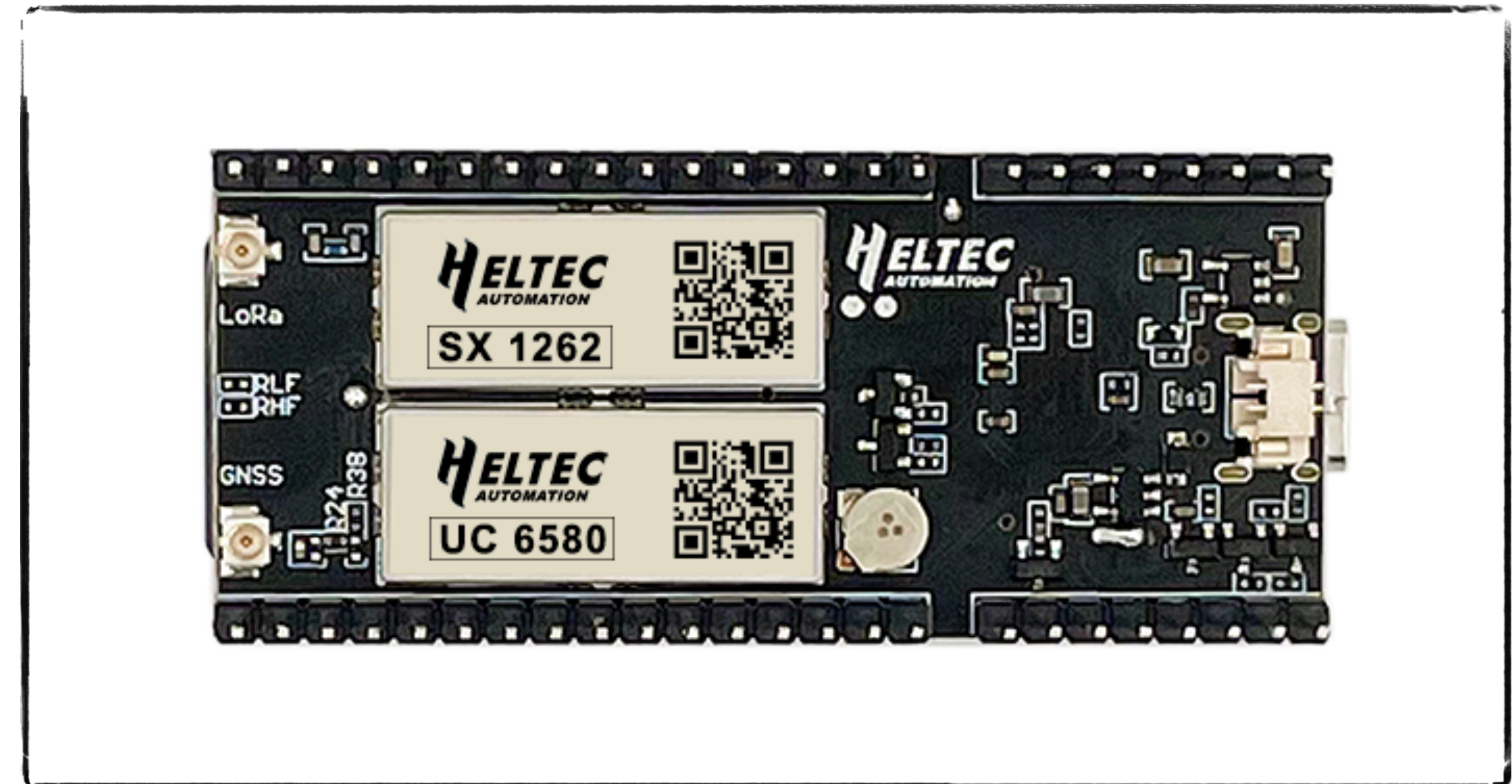

-- <https://heltec.org/project/Wireless-Tracker/>

-- <https://www.laskakit.cz/heltec-wireless-tracker-v1-1-868mhz-sx1262-uc6580-wifi-gps-modul/>

*) rather USB 2.0 via USB-C



Pixelure 10 dBi Gain/868MHz

-- <https://www.amazon.de/dp/B0F8VHHS1G>

Lightweight Design

Convenient Installation and Application

12cm/4.72inch

19.5cm/7.7inch

1cm/0.4inch

6cm/2.4inch

- 1
- 2
- 3



MESHTASTIC WEB FLASHER

Update your Meshtastic device with official firmware, straight from your browser

1





Select Target Device 

DEVICE

Plug in your device via USB. Please ensure the cable is not a power-only one.

2

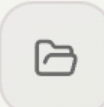

Select Firmware  

FIRMWARE

Choose from the release options or upload a release zip downloaded from Github.

3

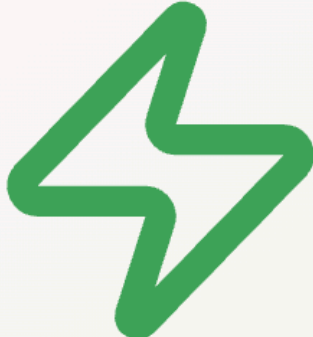

Flash

FLASH

Flash your device. Choose whether you wish to update your device or wipe the flash and install from scratch.









Select your connected device

All Devices RAK B&Q LilyGo Seeed Heltec Elecrow M5Stack NomadStar muzi WORKS

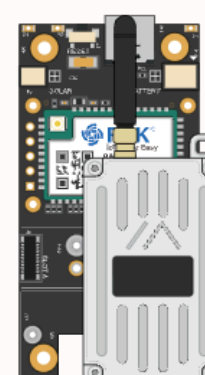
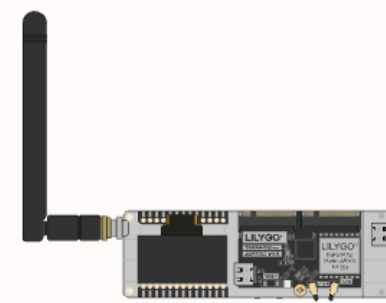
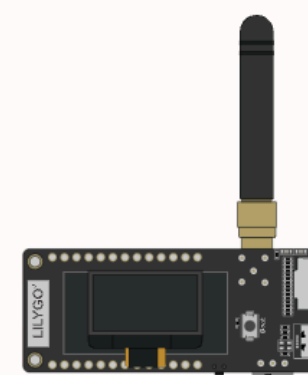
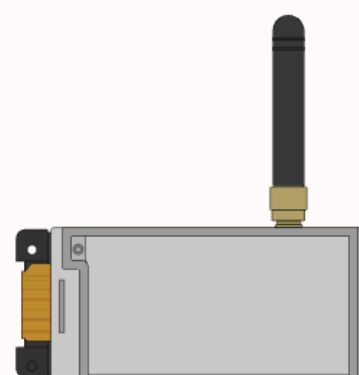
esp32 nrf52840 esp32-s3 rp2040 esp32-c3 esp32-c6

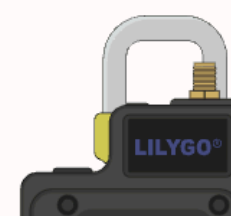
📄 If your connected device already has Meshtastic installed, you can automatically detect it: [Auto-detect](#)

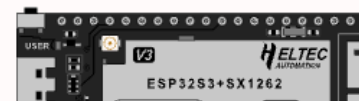
Supported Devices

LILYGO T-Echo ✓ nrf52840 LilyGo  ↻	RAK WisBlock 4631 ✓ nrf52840 RAK  ↻	LILYGO T-Beam Supreme ✓ esp32s3 LilyGo  ↻	LILYGO T-LoRa T3-S3 ✓ esp32s3 LilyGo  ↻	LILYGO T-LoRa T3-S3 E-Ink ✓ esp32s3 LilyGo  ↻
RAK WisMesh Repeater ✓ nrf52840 RAK  ↻	LILYGO T-Echo Plus ✓ nrf52840 LilyGo  ↻	Heltec V3 ✓ esp32s3 Heltec  ↻	Heltec Wireless Stick Lite V3 ✓ esp32s3 Heltec  ↻	Heltec Wireless Tracker V1.1 ✓ esp32s3 Heltec  ↻



After flashing FW, connect the device to the client application (BLE)

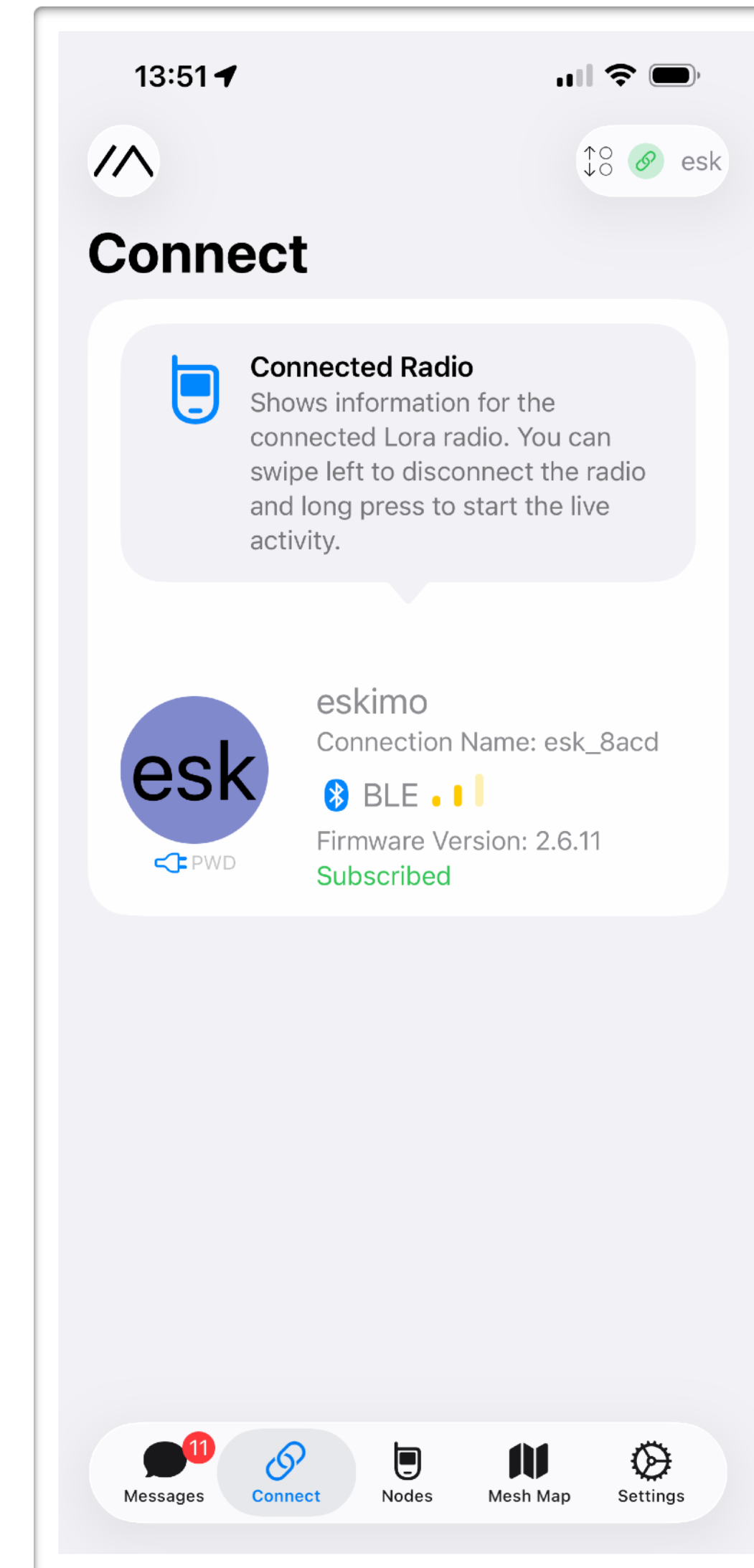
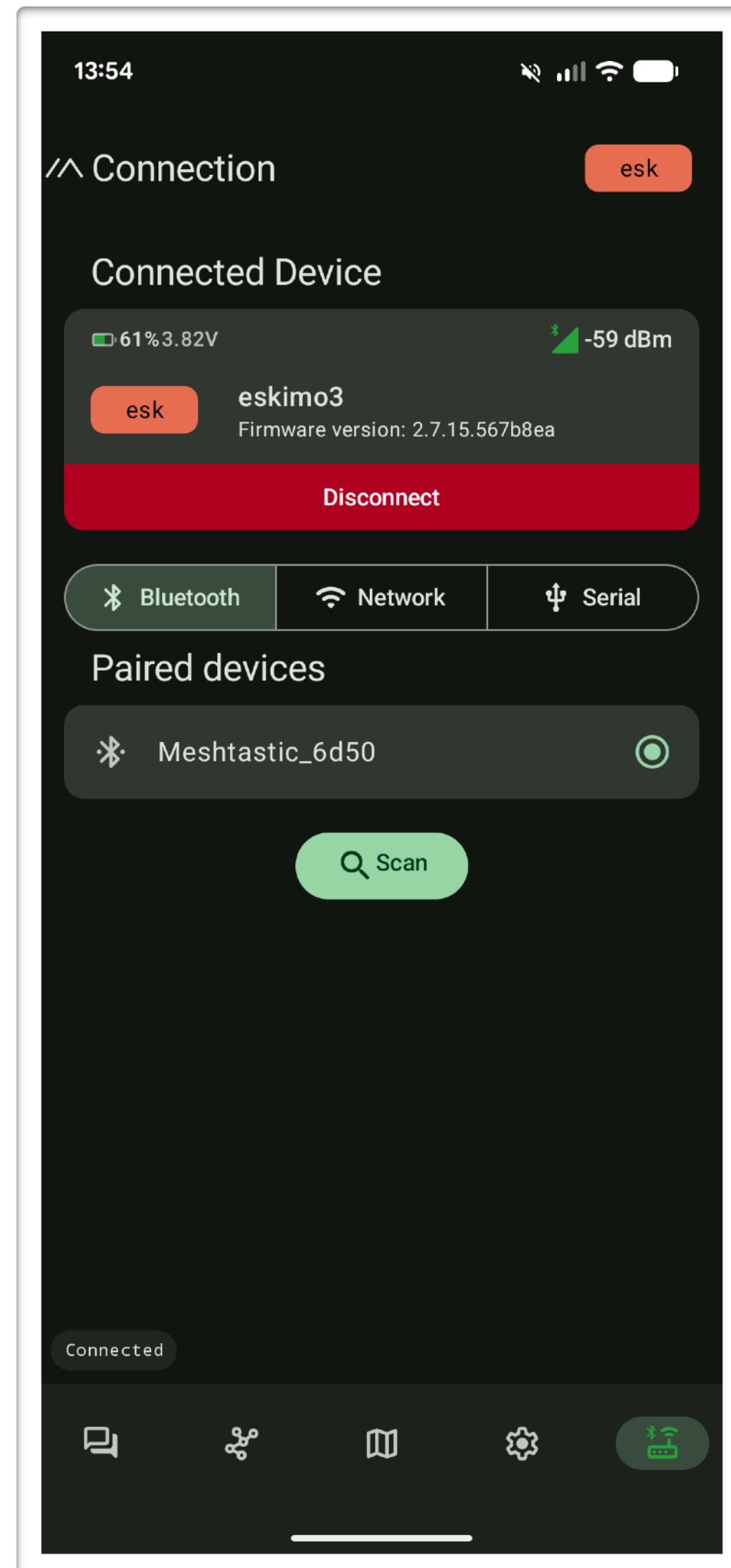

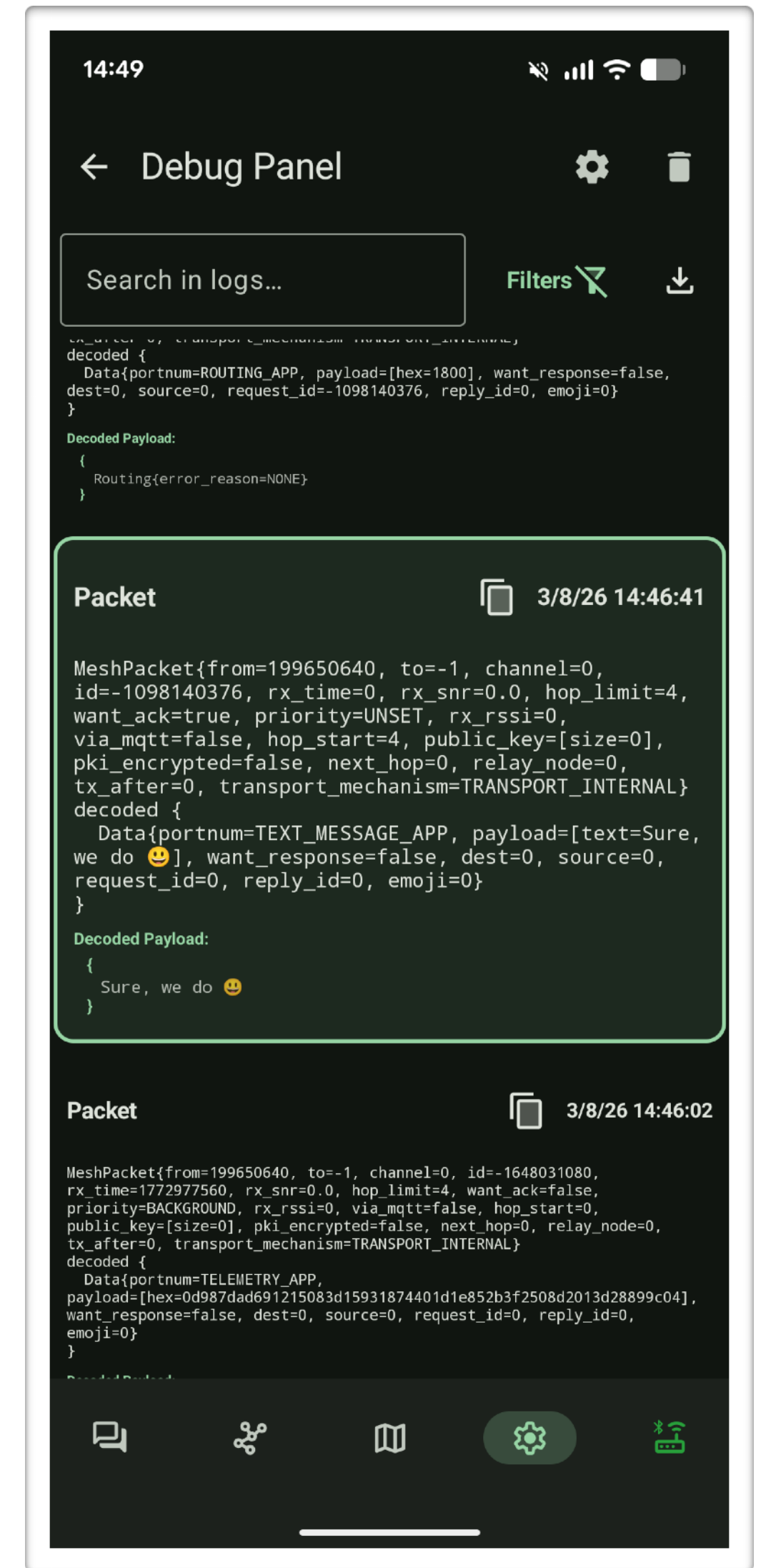
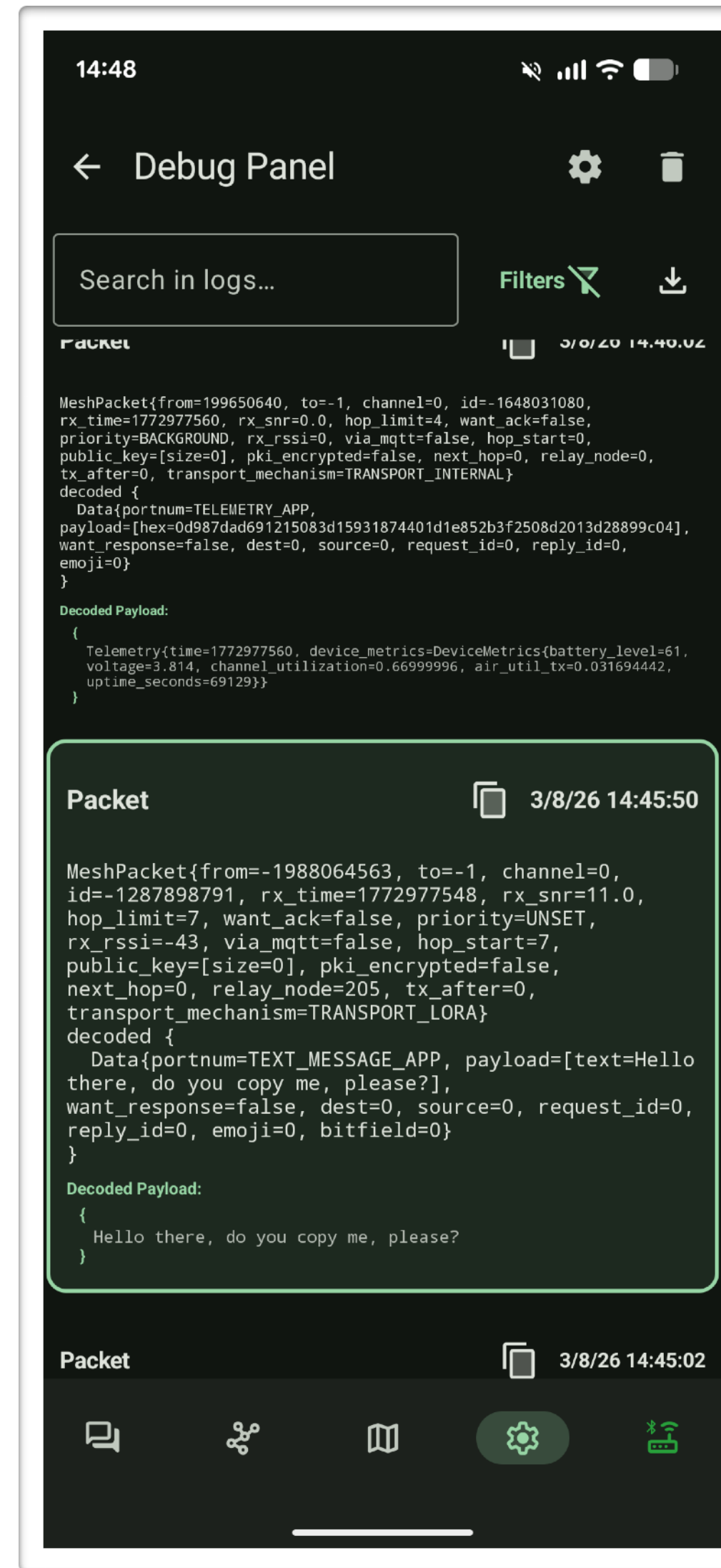
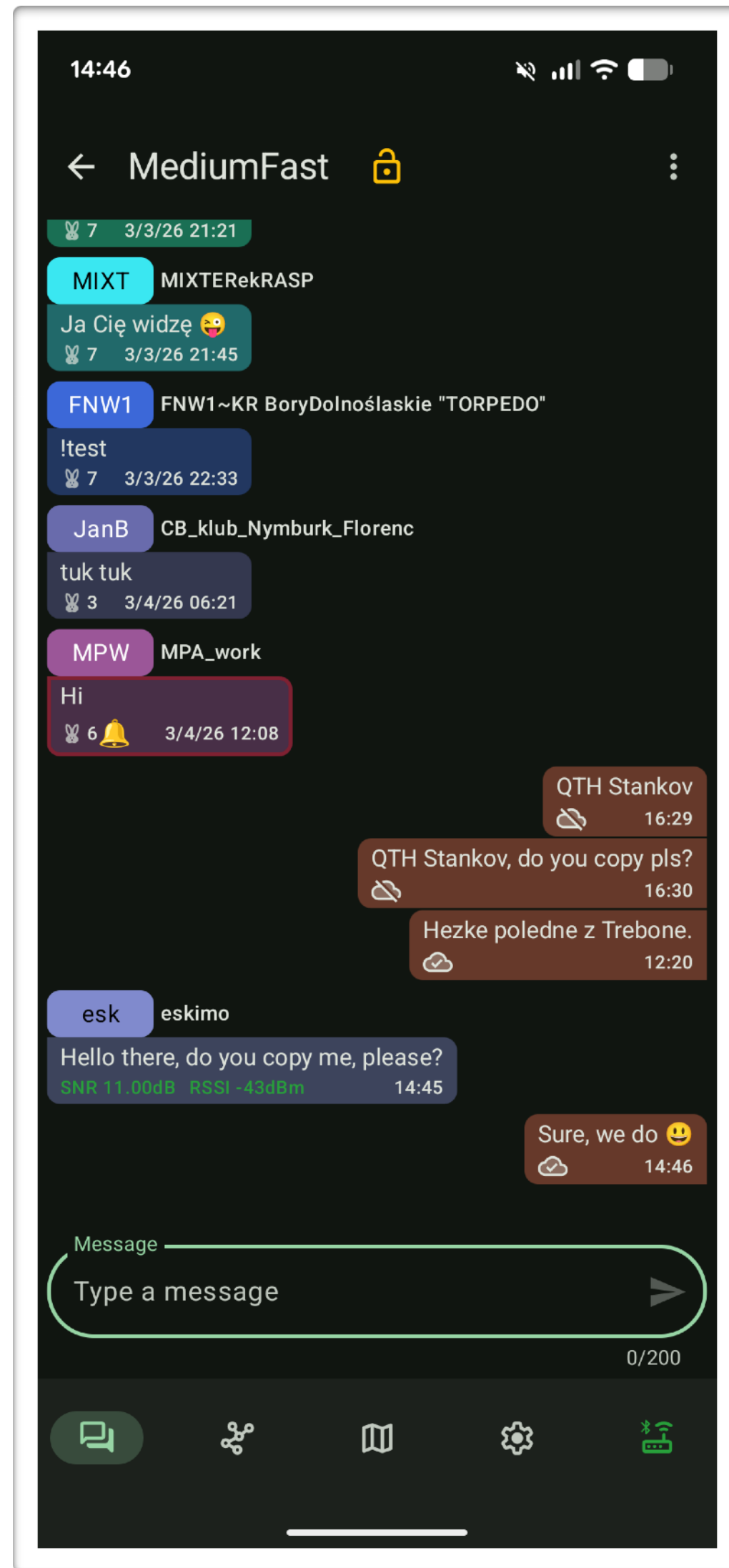
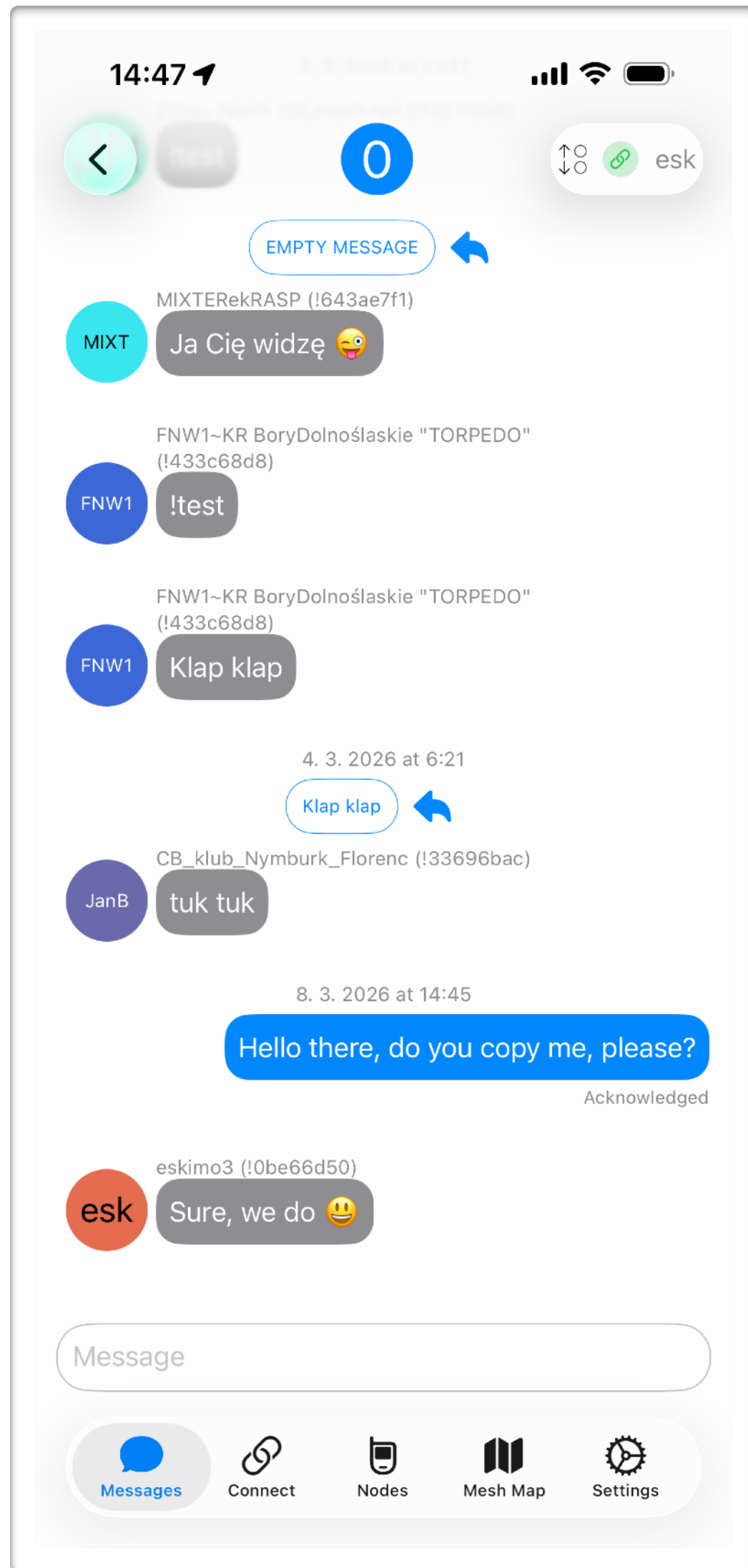

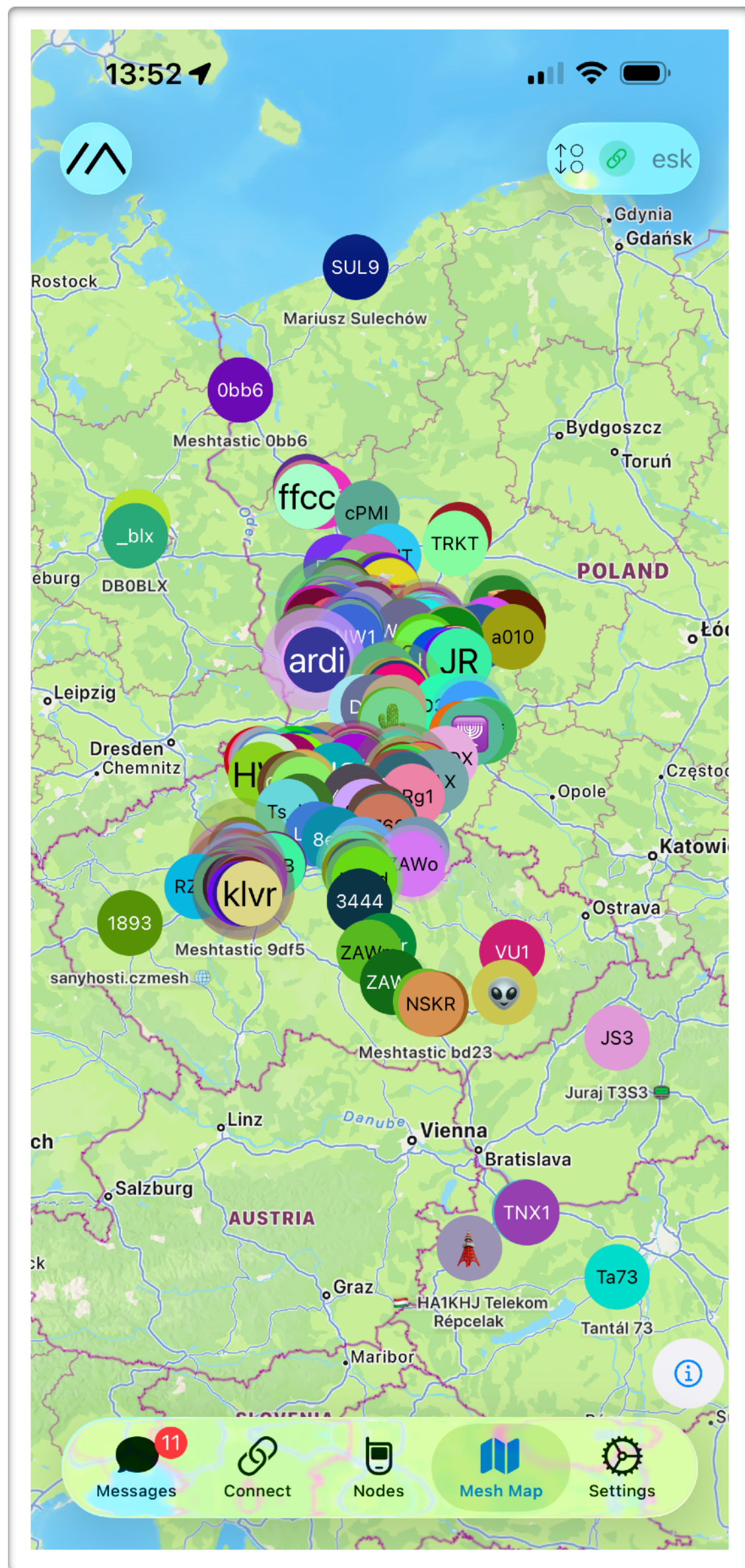

Prague, CZ, medium fast

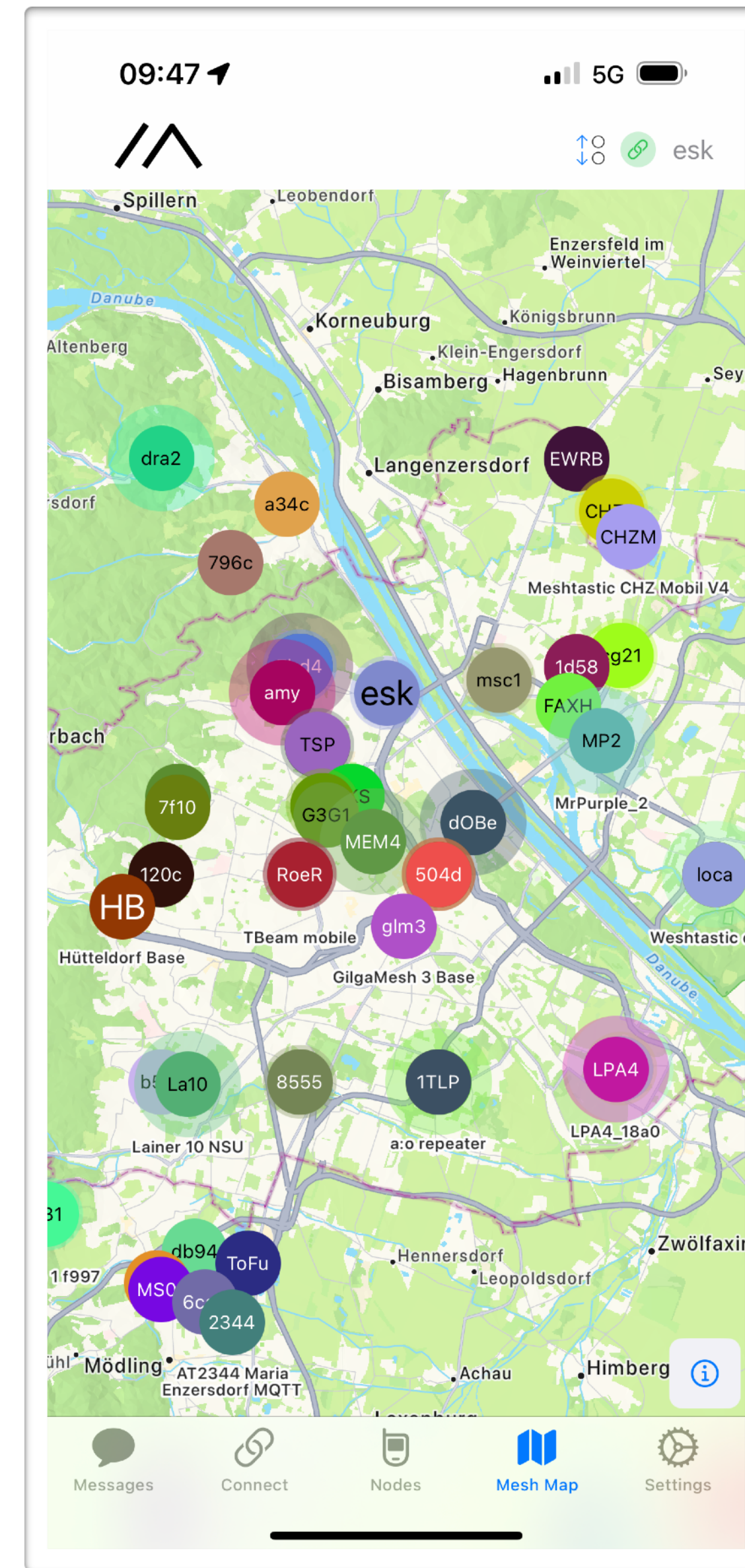

Vienna, AT, long fast



contact
received
7.3.2026
cca 27 km
RSSI -121 dBm
SNR -13.25 dB

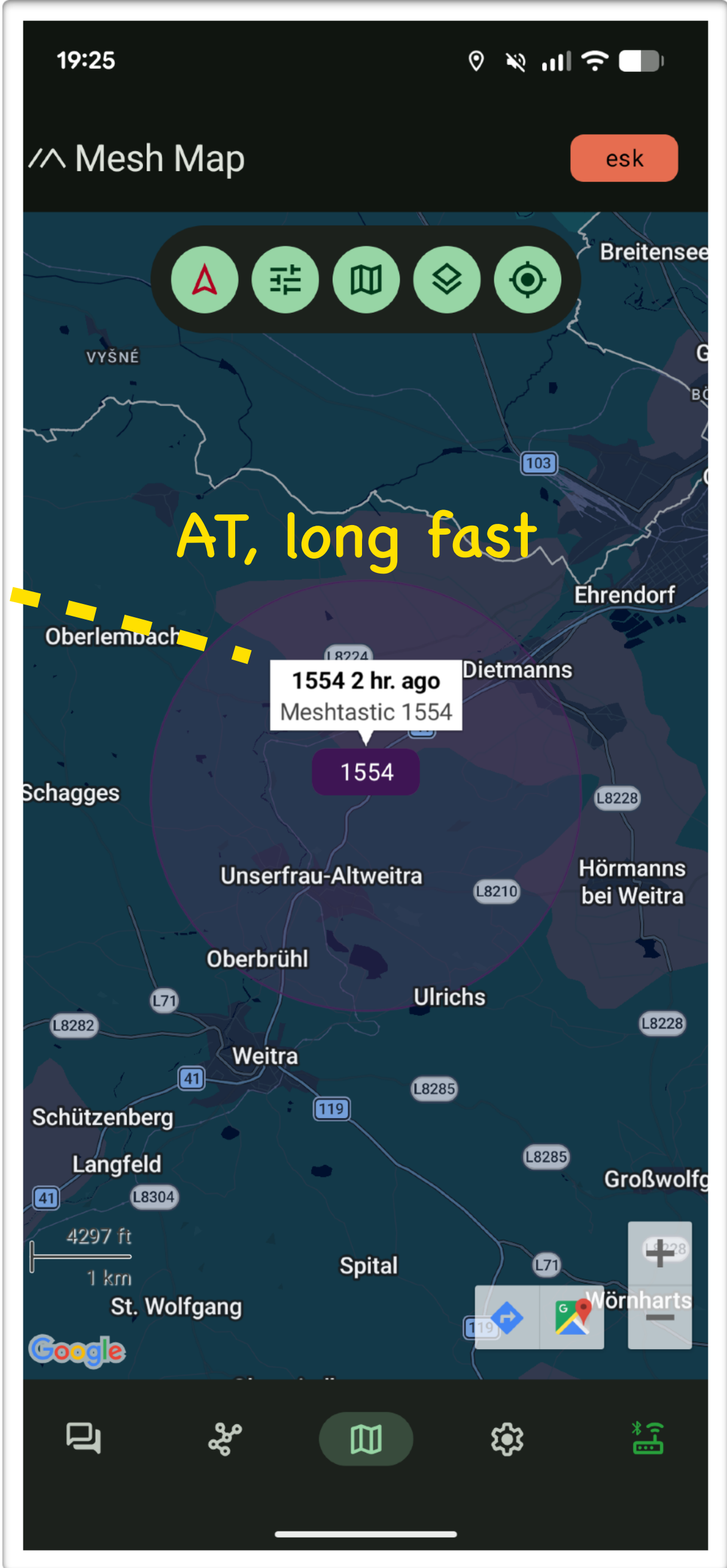

Thank you for your attention ///... //..\\ ...



**Co-funded by
the European Union**



ECCC 
EUROPEAN CYBERSECURITY
COMPETENCE CENTRE

Co-funded by the European Union

Views and opinions expressed are however those of the author(s) only and do not necessarily reflect those of the European Union or the European Cybersecurity Competence Centre. Neither the European Union nor the European Cybersecurity Competence Centre can be held responsible for them

Supported by ECCC

The project funded under Grant Agreement No. 101158662 is supported by the European Cybersecurity Competence Centre

History (year-month-day format)

- 2026-03-27, version 1.1, symbols annotated
- 2026-03-20, version 1.0 released